



2015 IECC Commercial Mechanical Requirements

- Energy codes and standards set minimum efficiency requirements for new and renovated buildings, assuring reductions in energy use and emissions over the life of the building. Energy codes are a subset of building codes, which establish baseline requirements and govern building construction.
- Code buildings are more comfortable and cost-effective to operate, assuring energy, economic and environmental benefits.

Commercial Compliance Options

1

● ASHRAE 90.1-2013

2

2015 IECC - Prescriptive

- C402 - Envelope
- C403 - Mechanical
- C404 - SWH
- C405 - Lighting

OR

OR

3

2015 IECC - Performance

- C407 – Total Building Performance
- C402.5 – Air Leakage
- C403.2 – Provisions applicable to all mechanical systems

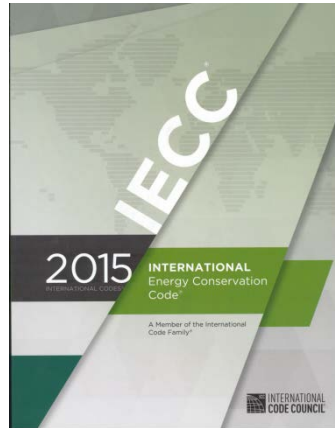

AND

● Pick One C406:

C406.2 – Eff. HVAC Performance

OR

C406.3 – Reduced Lighting Power Density

OR

C406.4 – Enhanced Lighting Controls

OR

C406.5 – On-site Supply of Renewable energy

OR

C406.6 – Dedicated Outdoor Air System

OR

C406.7 – High Eff. Service Water Heating

● C404 - SWH

● Lighting Mandatory Sections

C405.2

C405.3

C405.4

C405.6

● Building energy cost to be $\leq 85\%$ of standard reference design building

Additional Efficiency Package Options

Section C406

- One additional efficiency feature must be selected to comply with the IECC
 - **More efficient HVAC performance**, OR
 - Reduced lighting power density system, OR
 - Enhanced lighting controls, OR
 - **On-site supply of renewable energy**
 - **Dedicated outdoor air system**, OR
 - **More efficient SWH**



High Efficiency HVAC



More Efficient Lighting System



Onsite Renewables

- Efficient HVAC performance per C406.2 **OR**
 - Per Tables C403.2.3(1) thru C403.2.3(7)
 - Only used when efficiencies in the above tables are greater than 10% in addition to the requirements in C403
 - Where multiple performance requirements are provided, the equipment shall exceed all requirements by 10%
 - VRF's exceed energy efficiency provisions of 90.1-2013 by 10%
 - Equipment not listed in tables above shall be limited to 10% of total building system capacity

- On-site renewable energy per C406.5 **OR**
 - Total minimum ratings to comply with
 - Provide ≥ 1.75 Btu or ≥ 0.50 watts per ft² of conditioned floor area
OR
 - Provide $\geq 3\%$ of energy used for mechanical and SWH equipment and lighting
- Dedicated outdoor air system per C406.6 **OR**
 - For multi-zone/hydronic HVAC systems covered by C403.4
 - Be equipped with an independent ventilation system designed to provide $\leq 100\%$ outdoor air to each occupied space
 - Ventilation system capable of total energy recovery
 - HVAC system include supply-air temperature controls that automatically reset the supply-air temp. in response to building loads or outdoor air temperatures
 - Controls reset the supply-air temp. at least 25% of the difference between design supply-air temp. and design room-air temp.

- Reduced energy use in SWH per C406.7

Buildings with the following types allowed to use this compliance method:

- Group R-1: Boarding houses, hotels, or motels
- Group I-2: Hospitals, psychiatric hospitals, and nursing homes
- Group A-2: Restaurants and banquet halls or buildings containing food preparation areas
- Group F: Laundries
- Group R-2: Buildings with residential occupancies
- Group A-3: Health clubs and spas
- Buildings showing a SWH load of $\geq 10\%$ of total building energy loads as shown with an energy analysis per C407

- Reduced energy use in SWH (cont'd.)

Load fraction:

Building SWH has ≥ 1 of the following sized to provide $> 60\%$ of hot water requirements or sized to provide 100% of hot water requirements if building complies with C403.4.7

- Waste heat recovery from SWH, heat recover chillers, building equipment, process, equipment, or combined heat and power system
- Solar water-heating systems

Does My Project Need to Comply with the IECC?

All Buildings Other Than:

- ✓ One- and two-family residential
- ✓ R-2, R-3, R-4 three stories or less in height



Codes and standards listed in Chapter 6 are considered part of the requirements of this code to the “prescribed extent of each such reference and as further regulated in Sections C106.1.1 and C106.1.2”

- Conflicts, C106.1.1 – where differences occur between this code and the referenced codes and standards, provisions of this code apply
- Provisions in reference codes and standards, C106.1.2 – “where the extent of the reference to a referenced code or standard includes subject matter that is within the scope of this code, the provisions of this code, as applicable, shall take precedence over the provisions in the referenced code or standard”

Systems and equipment serving the building heating, cooling, and ventilation needs to comply with C403.2 and Sections C403.3 and C403.4 based on the equipment and systems provided

Walk-in coolers, walk-in freezers, refrigerated warehouse coolers and refrigerated warehouse freezers shall comply with Section 403.2.15 or 403.2.16

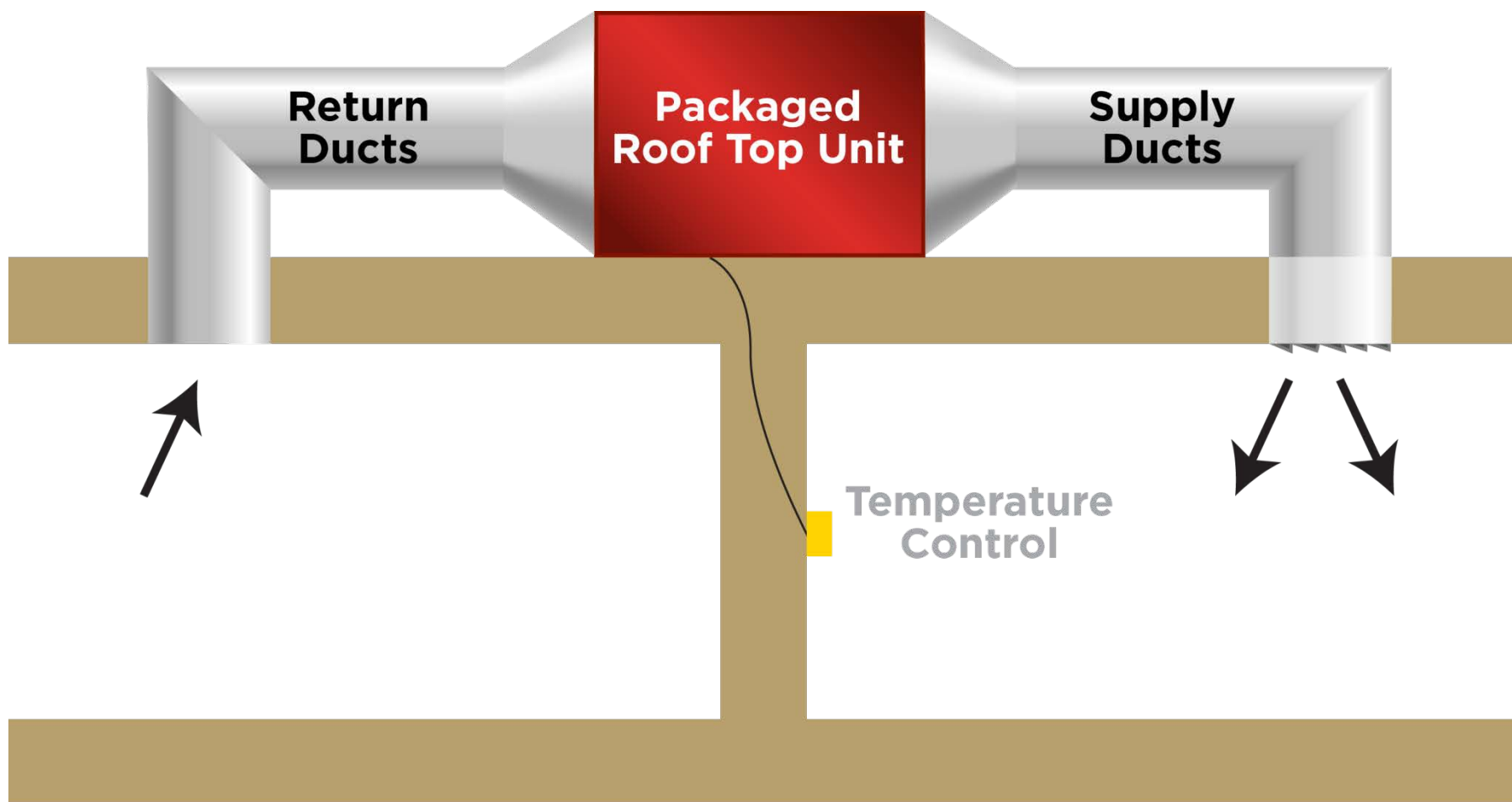

Simple System

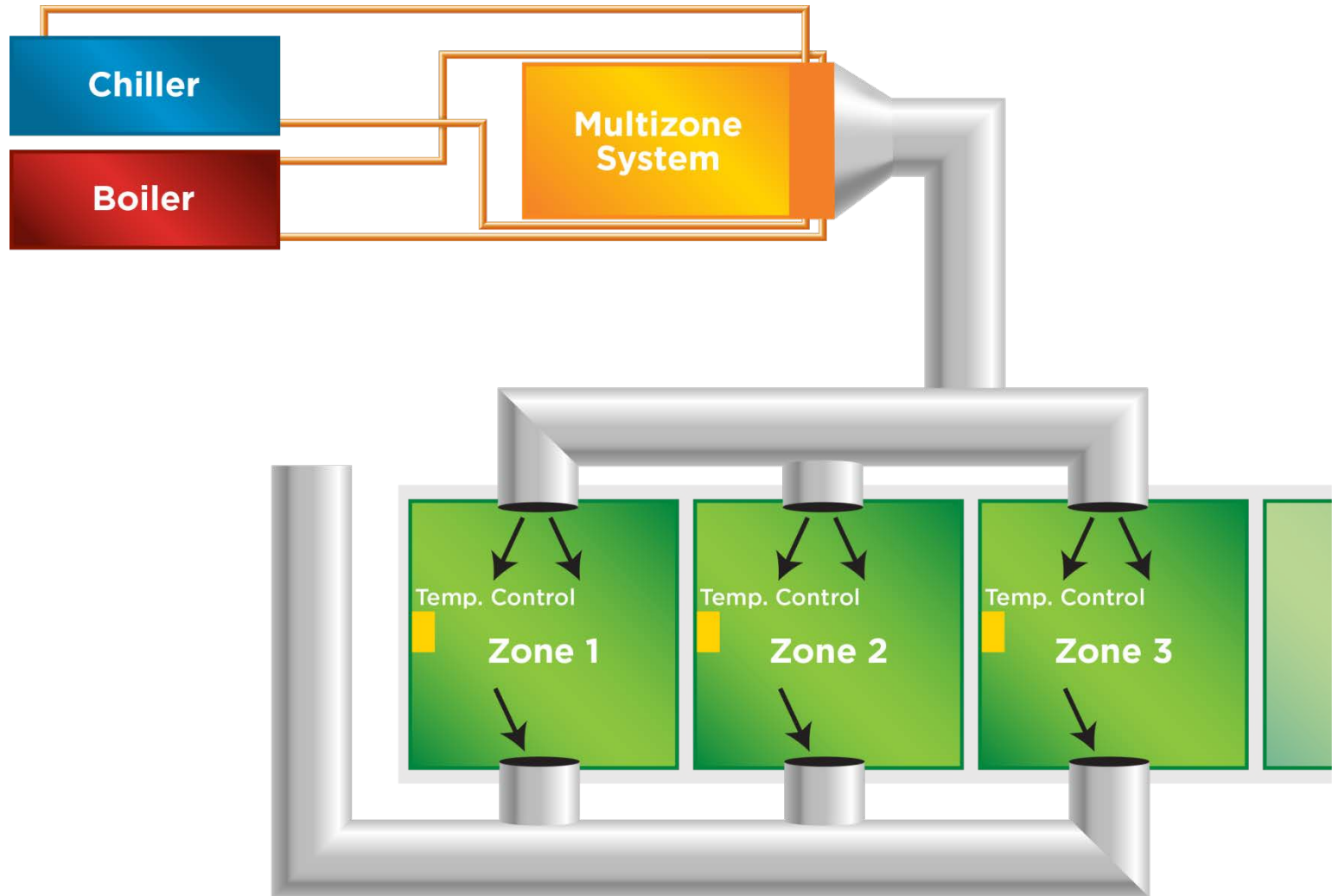

Provisions Applicable to ALL Mechanical Systems

- ✓ HVAC Load Calculations
- ✓ Equipment and System Sizing
- ✓ HVAC Equipment Performance Requirements
- ✓ HVAC System Controls
- ✓ Hot Water Boiler Outdoor Temp. Set-back Control
- ✓ Ventilation
- ✓ Energy Recovery Ventilation Systems
- ✓ Kitchen Exhaust Systems
- ✓ Duct and Plenum Insulation and Sealing
- ✓ Piping Insulation
- ✓ HVAC System Commissioning and Completion
- ✓ Air System Design and Control
- ✓ Heating Outside a Building
- ✓ Refrigeration Equipment Performance
- ✓ Walk-in Coolers and Freezers, Refrigerated Warehouse Coolers and Freezers
- ✓ Walk-in Coolers and Walk-in Freezers

Heating and cooling load sizing calculations required

- ✓ ASHRAE/ACCA Standard 183 OR
- ✓ Other approved computation procedures – defined in Chapter 3
 - Interior design conditions
 - Specified by Section C302 of the IECC
 - $\leq 72^{\circ}\text{F}$ for heating load
 - $\geq 75^{\circ}\text{F}$ for cooling load
- ✓ Loads reduced from energy recovery systems utilized in the HVAC system shall be accounted for in accordance with the ASHRAE HVAC Systems and Equipment Handbook

Output capacity of heating and cooling equipment only
SHALL NOT be greater than calculated loads

- ✓ Select the system which serves the greater load, heating or cooling
 - **Exceptions:**
 - Standby Equipment with Required Controls
 - Multiple Units with Combined Capacities Exceeding Loads
 - Sequencing Controls Required

Applies to all equipment used in heating and cooling of buildings

- ✓ Where components from different manufacturers are used
 - calculations and supporting data demonstrating combined efficiency meets requirements

Must comply with all listed efficiencies

- Equipment not designed for operation at AHRI Standard 550/590 test conditions of 44°F leaving chilled-water temperature and 2.4 gpm/ton evaporator fluid flow and 85°F entering condenser water temperature with 3 gpm/ton condenser water flow
 - To have maximum full-load kW/ton and NPLV ratings adjusted using Equations 4-6 and 4-7
- The FL_{adj} and PLV_{adj} values are only applicable for centrifugal chillers meeting all of these full-load design ranges
 - Evaporator leaving temperature $\geq 36^{\circ}\text{F}$
 - Condenser leaving temperature $\leq 115^{\circ}\text{F}$
 - $20^{\circ}\text{F} \leq \text{LIFT} \leq 80^{\circ}\text{F}$

Table C403.2.3(2)

Mandatory

EQUIPMENT TYPE	SIZE CATEGORY	HEATING SECTION TYPE	SUBCATEGORY OR RATING CONDITION	MINIMUM EFFICIENCY		TEST PROCEDURE
				Before 1/1/2016	As of 1/1/2016	
Air cooled (cooling mode)	< 65,000 Btu/h	All	Split system	13.0 SEER	14.0 SEER	AHRI 210/240
			Single packaged	13.0 SEER	14.0 SEER	
Through-the-wall air cooled	≤ 30,000 Btu/h	All	Split system	12.0 SEER	12.0 SEER	
			Single packaged	12.0 SEER	12.0 SEER	
Single-duct high-velocity air cooled	< 65,000 Btu/h	All	Split system	11.0 SEER	11.0 SEER	

Positive Displacement (Air- and Water-Cooled Chilling Packages)

Section C403.2.3.2

- Equipment with a leaving fluid temperature $> 32^{\circ}\text{F}$ and water-cooled positive displacement chilling packages with a condenser leaving fluid temperature $< 115^{\circ}\text{F}$ to meet Table C403.2.3(7)
 - when tested or certified with water at standard rating conditions, in accordance with the referenced test procedure

System Controls

Section C403.2.4 (Mandatory)

Control required for each system

- ✓ if zoned for each zone





Heat pump systems

- ✓ Heat pump thermostat required when supplying electric resistance heating
- ✓ Control must prevent supplemental heat demand when heat pump can meet the heating load.
 - Except during defrost

Thermostats must have at least a 5°F deadband

✓ **Exception:**

- Thermostats requiring manual change over between heating and cooling
- Occupancies or applications requiring precision in indoor temperature control as approved by code official

- Where separate thermostatic control device for heating and separate cooling in a zone:
 - Limit switch
 - Mechanical stop OR
 - Direct digital control system with software programming shall be provided with capability to prevent heating set point from exceeding cooling set point to maintain deadband

Automatic time clock or programmable system

✓ **Exceptions:**

- Zones operated continually
- Zones with full HVAC load demand <6,800 Btu/h and has a readily accessible shut off switch

Thermostatic setback capabilities

- ✓ Capability to maintain zone temps down to 55°F or up to 85°F

Automatic setback and shutdown

- ✓ Seven different daily schedules/week
- ✓ Retain programming \geq 10 hrs with loss of power **AND**
 - ✓ Manual override up to 2 hours **OR**
 - ✓ Manual timer capable of operating up to 2 hours **OR**
 - ✓ Occupancy sensor

Automatic start controls for each HVAC system

- ✓ Capable of automatically adjusting daily start time to bring each space to desired occupied temperature immediately prior to scheduled occupancy

Controls (Mandatory)

Section C403.2.4.3 Shutoff Dampers

- Outdoor air intake and exhaust openings and stairway and shaft vents provided with Class I motorized dampers
- Dampers with air leakage rate ≤ 4 cfm ft² of damper surface at 1.0 inch water gauge (249 Pa) and labeled and approved in accordance with AMCA 500D
- Outdoor air intake and exhaust dampers with automatic controls configured to close the systems or spaces served when not in use or during unoccupied period warm-up and setback operation
 - Unless systems served require outdoor or exhaust air per IMC OR
 - Dampers are opened to provide intentional economizer cooling

Controls (Mandatory)

Section C403.2.4.3 Shutoff Dampers – Cont'd.

- Stairway and shaft vent dampers installed with automatic controls configured to open up on activation of any fire alarm initiating device of the building's fire alarm system or the interruption of power to the damper
 - ✓ **Exceptions:**
 - Gravity dampers permitted in buildings < 3 stories
 - Gravity dampers permitted for buildings of any height located in **Climate Zones 1-3**
 - Gravity dampers permitted for outside air intake or exhaust airflows of 300 cfm (0.14m³/s) or less

Controls (Mandatory)

Section C403.2.4.3 Shutoff Dampers – Cont'd.

- Gravity motorized dampers shall have an air leakage rate:
 - ≤ 20 cfm/ft² where > 24 inches in either dimension
 - 40 cfm/ft² where < 24 inches in either dimension
- Air leakage rate determined at 1.0 inch water gauge (249 Pa) when tested in accordance with AMCA 500D
- Dampers labeled by an approved agency

Controls (Mandatory)

Section C403.2.4.4 Zone Isolation

Divided into isolation areas:

- HVAC systems serving zones > 25,000 ft² in floor area OR
- Span > one floor and are designed to operate or be occupied nonsimultaneously

Isolation areas:

- Isolation devices and controls configured to automatically shut off the supply of conditioned air and outdoor air to and exhaust air from the isolation area
- Controlled independently meeting C403.2.4.2.2
- Central systems and plants provided with controls and devices that will allow system and equipment operation for any length of time while serving the smallest isolation area served by system or plant

Exceptions:

- Exhaust air and outdoor air connections to isolation areas where the fan system to which they connect is $< 5,000$ cfm
- Exhaust airflow from a single isolation area of $< 10\%$ of the design airflow of the exhaust system to which it connects
- Isolation areas intended to operate continuously or intended to be inoperative only when all other isolation areas in a zone are inoperative

Controls (Mandatory)

Section C403.2.4.5 Snow Melt Systems

Snow- and ice-melting systems, supplied through energy service to the building, shall include

- ✓ automatic controls capable of shutting off the system when the pavement temperature is above 50°F (10°C) and no precipitation is falling
- ✓ an automatic or manual control that will allow shutoff when the outdoor temperature is above 40°F (4°C)



Photo courtesy of Ken Baker, K energy

Controls (Mandatory)

Section C403.2.4.6 Freeze Protection System

Systems such as heat tracing of outdoor piping and heat exchangers, including self-regulated heat tracing to include:

- Automatic controls configured to shut off the system when outdoor air temperatures are $> 40^{\circ}\text{F}$ (4°C) OR
- When conditions of the protected fluid will prevent freezing

- Air cooled unitary direct-expansion units (listed in Tables C403.2.3(1-3) and variable refrigerant flow (VRF) units that are equipped with an economizer per Section C403.3 to include a fault detection and diagnostics (FDD) system complying with the following:
 - Temperature sensors permanently installed to monitor system operation
 - Outside air
 - Supply air
 - Return air
 - Temperature sensors have an accuracy of $\pm 2^{\circ}\text{F}$ over the range of 40°F - 80°F
 - Refrigerant pressure sensors, where used, have an accuracy of $\pm 3\%$ of full scale

- Unit controller capable of providing system status by indicated the following:
 - Free cooling available
 - Economizer enabled
 - Compressor enabled
 - Heating enabled
 - Mixed air low limit cycle active
 - Current value of each sensor
- Unit controller capable of manually initiating each operating mode so that the operation of compressors, economizers, fans and heating system can be independently tested and verified

Controls (Mandatory)

Section C403.2.4.7 Economizer Fault

Detection and Diagnostics – Cont'd.

- Unit capable of reporting faults to a fault management application accessible by day-to-day operating or service personnel, or annunciated locally on zone thermostats
- The FDD system capable of detecting the following faults:
 - Air temperature sensor failure/fault
 - Not economizing when the unit should be economizing
 - Economizing when the unit should not be economizing
 - Damper not modulating
 - Excess outdoor air

- Hot water boilers that supply heat to the building through one or two-pipe heating systems shall have an outdoor setback control that lowers the boiler water temperature based on the outdoor temperature

Demand Controlled Ventilation

Section C403.2.6.1 (Mandatory)

DCV must be provided for each zone with spaces $> 500 \text{ ft}^2$ and the average occupant load ≥ 25 people/1000 ft^2 of floor area where the HVAC system has:

- ✓ An air-side economizer, **or**
- ✓ Automatic modulating control of the outdoor air damper, **or**
- ✓ A design outdoor airflow $> 3,000 \text{ cfm}$

Demand control ventilation (DCV): a ventilation system capability that provides for the automatic reduction of outdoor air intake below design rates when the actual occupancy of spaces served by the system is less than design occupancy.

Exceptions:

- ✓ Systems with energy recovery per C403.2.6
- ✓ Multiple zone systems without direct digital control of single zones communicating with central control panel
- ✓ Systems with design outdoor airflow $< 1,200$ cfm
- ✓ Spaces where supply airflow rate minus any makeup or outgoing transfer air requirement $< 1,200$ cfm
- ✓ Ventilation provided for process loads only

Enclosed Parking Garage Ventilation Controls

Section C403.2.6.2 (Mandatory)

- Garages for storing or handling automobiles operating under their own power shall employ contamination-sensing devices and automatic controls configured to stage fans or modulate fan average airflow rates to $\leq 50\%$ of design capacity, or intermittently operate fans $< 20\%$ of occupied time or as required to maintain acceptable contaminant levels in accordance with IMC provisions
- Failure of these devices shall cause the exhaust fans to operate continuously at design airflow

Exceptions:

- Garages with total exhaust capacity $< 22,500$ cfm with ventilation systems that do not utilize heating or mechanical cooling
- Garages that have garage area to ventilation system motor nameplate power ratio $> 1,125$ cfm/hp and do not utilize heating or mechanical cooling

Energy Recovery Ventilation Systems

Section C403.2.7 (Mandatory)

- ✓ Applies to fan systems with supply airflow rates > values in Tables C403.2.7(1-2)
- ✓ Exhaust air total recovery efficiency must be $\geq 50\%$
- ✓ When an air economizer is required
 - include a bypass or controls that permit operation of economizer per C403.3

Energy recovery ventilation (ERV) systems: employ air-to-air heat exchangers to recover energy from exhaust air for the purpose of preheating, precooling, humidifying or dehumidifying outdoor ventilation air prior to supplying the air to a space, either directly or as part of an HVAC system.



Energy Recovery Ventilation Systems

Section C403.2.6 (Mandatory)

Exceptions:

- ✓ Where energy recovery ventilation systems prohibited by the IMC
- ✓ Lab fume hood system with at least one of the following:
 - VAV hood exhaust and room supply systems capable of reducing exhaust and makeup air volume to $\leq 50\%$ of design values
 - Direct makeup (auxiliary) air supply equal to at least 75% of exhaust rate, heated no warmer than 2°F below room setpoint, cooled to no cooler than 3°F above room setpoint, no humidification added, and no simultaneous heating and cooling use for dehumidification control
- ✓ Systems serving uncooled spaces and heated to $< 60^{\circ}\text{F}$
- ✓ Where $> 60\%$ of outdoor heating energy is from site-recovered or site solar energy
- ✓ Heating energy recovery in **Climate Zones 1-2**
- ✓ Cooling energy recovery in **Climate Zones 3C, 4C, 5B, 5C, 6B, 7, and 8**
- ✓ Systems requiring dehumidification that employ energy recovery in series with the cooling coil
- ✓ Where largest source of air exhausted at a single location at building exterior is $< 75\%$ of design outside air flow rate
- ✓ Systems expected to operate < 20 hours/week at outdoor air % covered by Table C403.2.7(1)
- ✓ Systems exhausting toxic, flammable, paint or corrosive fumes or dust
- ✓ Commercial kitchen hoods used for collecting and removing grease vapors and smoke

- Replacement air introduced directly into the exhaust hood cavity shall not be $> 10\%$ of the hood exhaust airflow rate
- Conditioned supply air delivered to any space shall not exceed the greater of the following:
 - Ventilation rate required to meet the space heating or cooling load
 - Hood exhaust flow minus the available transfer air from adjacent space where available transfer air is considered that portion of outdoor ventilation air not required to satisfy other exhaust needs, such as restrooms, and not required to maintain pressurization of adjacent spaces

- Total kitchen hood exhaust flow rate $>5,000$ cfm, each hood be a factory built commercial exhaust hood listed by nationally recognized testing laboratory in compliance with UL 710
- Each hood shall have a maximum exhaust rate as specified in Table C403.2.8 and comply with one of the following:
 - Not $< 50\%$ of all replacement air shall be transfer air that would otherwise be exhausted
 - Demand ventilation systems on not $< 75\%$ of the exhaust air that are capable of not $< 50\%$ reduction in exhaust and replacement air system airflow rates including controls necessary to modulate airflow in response to appliance operation and maintain full capture and containment of smoke, effluent and combustion products during cooking and idle

- Listed energy recovery devices with a sensible heat recovery effectiveness not <40% on not <50% of the total exhaust airflow
 - Where a single hood, or hood section, is installed over appliances with different duty ratings, the maximum allowable flow rate for the hood or hood section shall be based on the requirements for the highest appliance duty rating under the hood or hood section
 - **Exception**: where not < 75% of the replacement air is transfer air that would otherwise be exhausted

Duct and Plenum Insulation & Sealing

Section C403.2.9 (Mandatory)



Insulation required for supply and return ducts and plenums

- ✓ Located in unconditioned space:
 - ✓ minimum R-6
- ✓ Duct located outside the building; duct or plenum within building envelope assembly shall be separated from building exterior or unconditioned or exempt spaces:
 - ✓ minimum R-8, **Climate Zones 1-4**
 - ✓ minimum R-12, **Climate Zones 5-8**

Exceptions:

- ✓ When located within equipment
- ✓ When design temperature difference between interior and exterior of the duct or plenum doesn't exceed 15°F

Low & Medium Pressure Duct Systems

Sections C403.2.9.1.1 and C403.2.9.1.2

(Mandatory)

Ducts designed to operate at static pressures ≤ 2 in. w.g.

Securely fastened and sealed

✓ **Exceptions:**

- When located within equipment
- Design temperature difference between interior and exterior of duct or plenum $<15^{\circ}\text{F}$

Ducts and plenums designed to operate at static pressures > 3 in. w.g. to be insulated and sealed and be leak tested in accordance with SMACNA HVAC Air Duct Leakage Test Manual

- ✓ Air leakage rate ≤ 4.0
- ✓ $CL = F/P^{0.65}$
 - Where
 - F = leakage rate cfm per 100 sf of duct surface area
 - P = the static pressure of the test

Must test $\geq 25\%$ of the duct area and meet the requirements

Piping Insulation

Section C403.2.10 (Mandatory)

All piping serving heating or cooling system must be insulated in accordance with Table C403.2.10

Minimum Pipe Insulation
(thickness in inches)

FLUID OPERATING TEMPERATURE RANGE AND USAGE (°F)	INSULATION CONDUCTIVITY		NOMINAL PIPE OR TUBE SIZE (Inches)				
	Conductivity Btu · in./ (h · ft ² · °F) ^a	Mean Rating Temperature, °F	< 1	1 to < 1½	1½ to < 4	4 to < 8	≤ 8
> 350	0.32 – 0.34	250	4.5	5.0	5.0	5.0	5.0
251 – 350	0.29 – 0.32	200	3.0	4.0	4.5	4.5	4.5
201 – 250	0.27 – 0.30	150	2.5	2.5	2.5	3.0	3.0

(Partial table)

Exceptions:

- ✓ Piping internal to HVAC equipment (*including fan coil units*) factory installed and tested
- ✓ Piping for fluid in temperature range
 $60\text{ }^{\circ}\text{F} < \text{temp} < 105\text{ }^{\circ}\text{F}$
- ✓ Piping for fluid not heated or cooled by electricity or fossil fuels
- ✓ Strainers, control valves, and balancing valves associated with piping ≤ 1 " in diameter
- ✓ Direct buried piping for fluids $\leq 60\text{ }^{\circ}\text{F}$

Mechanical Systems

Commissioning and Completion

Section C403.2.11 (Mandatory)

Mechanical system to be commissioned and completed per
Section C408.2

Air System Design and Control

Section C403.2.12 (Mandatory)

- ✓ Maximum fan power requirements
- ✓ Applies to HVAC systems with total fan system power > 5 hp
- ✓ Each HVAC system at design conditions can not exceed allowable fan system motor nameplate hp (Option 1) or fan system bhp (Options 2) in Table C403.2.12.1(1)
- ✓ Single zone VAV systems to comply with constant volume fan power limitations

TABLE C403.2.12.1.1(1) FAN POWER LIMITATION

	LIMIT	CONSTANT VOLUME	VARIABLE VOLUME
Option 1: Fan System Motor Nameplate hp	Allowable Nameplate Motor hp	$hp \leq CFMS * 0.0011$	$hp \leq CFMS * 0.0015$
Option 2: Fan System bhp	Allowable Fan System bhp	$bhp \leq CFMS * 0.00094 + A$	$bhp \leq CFMS * 0.0013 + A$

Allowable Fan Motor Horsepower

Section C403.2.12.1 (Mandatory)

BHP option includes adjustment “adders” and “deducts” for certain devices

Single-zone variable air volume systems shall comply with the constant volume fan power limitation

Table C403.1.12.1(2)
Fan Power Limitation Pressure Drop Adjustment

DEVICE	ADJUSTMENT
Credits	
Fully ducted return and/or exhaust air systems	0.5 in w.c. (2.15 in w.c. for laboratory and vivarium systems)
Return and/or exhaust air flow control devices	0.5 in w.c.
Exhaust filters, scrubbers, or other exhaust treatment.	The pressure drop of device calculated at fan system design condition.
Particulate Filtration Credit: MERV 9 thru 12	0.5 in w.c.
Particulate Filtration Credit: MERV 13 thru 15	0.9 in w.c.
Particulate Filtration Credit: MERV 16 and greater and electronically enhanced filters	Pressure drop calculated at 2x clean filter pressure drop at fan system design condition.
Carbon and Other gas-phase air cleaners	Clean filter pressure drop at fan system design condition.

(Partial table)

Allowable Fan Motor Horsepower

Section C403.2.12.1 (Mandatory)

Exceptions:

- ✓ Hospital, vivarium, and laboratory systems using flow control devices on exhaust and/or return for health and safety or environmental control permitted to use variable fan power limitation
- ✓ Individual exhaust fans with motor nameplate ≤ 1 hp

Motor Nameplate Horsepower

Section C403.2.12.2 (Mandatory)

Selected fan motor to be no larger than first available motor size greater than bhp

Fan bhp on design documents

Exceptions

- ✓ Fans < 6 bhp, where first available motor larger than bhp has nameplate rating within 50% of bhp, next larger nameplate motor size may be selected
Example: 5.2 Bhp; next size of 7.5 is within $1.5 * \text{Bhp}$ (7.8)
so may upsize to 10 HP, or next size after 7.5 HP
- ✓ Fans ≥ 6 bhp, where first available motor larger than bhp has nameplate rating within 30% of bhp, next larger nameplate motor size may be selected

bhp = brake horsepower

- Have a fan efficiency grade (FEG) < 67 when determined in accordance with AMCA 205 by an approved independent testing laboratory or labeled by the manufacturer
- Total efficiency at the design point of operation be within 15 percentage points of the max. total efficiency of the fan
- **Exceptions:**
 - Fans of ≤ 5 hp
 - Single fan with a motor nameplate horsepower of ≤ 5 hp UNLESS
 - Multiple fans in a series or parallel that have a combined motor nameplate horsepower ≤ 5 hp and are operated as the functional equivalent of a single fan

Exceptions (cont'd)

- Fans that are part of the equipment covered under Section C403.2.3
- Fans included in an equipment package certified by an approved agency for air or energy performance
- Powered wall/roof ventilators
- Fans outside the scope of AMCA 205
- Fans that are intended to operate only during emergency conditions

Systems are to be radiant systems

Controlled by an occupancy sensing device or timer switch

- ✓ So system is automatically deenergized when no occupants are present

- Equipment have an energy use in kWh/day \leq the values of Tables C403.2.14(1-2) when tested and rated in accordance with AHRI Standard 1200
- Energy use shall be verified through certification under an approved certification program or where a certification program does not exist, the energy use shall be supported by data furnished by the equipment manufacturer

- Be equipped with automatic door-closers that firmly close walk-in doors that have been closed to within 1” of full closure
 - **Exception** – automatic closers are not required for doors >45” in width or > 7ft in height
- Doorways have strip doors, curtain, spring hinged doors or other approved method of minimizing infiltration when doors are open
- Walk-in coolers and refrigerated warehouse coolers shall have wall, ceiling, and door insulation of \geq R-25 and walk-in freezers and refrigerated warehouse freezers \geq R-32
 - **Exception** – glazed portions of doors or structural members need not be insulated

- Walk-in freezers contain floor insulation \geq R-28
- Transparent reach-in doors for walk-in freezers and windows in walk-in freezer doors shall be of triple-pane glass, either filled with inert gas or with heat-reflective treated glass
- Windows and transparent reach-in doors for walk-in coolers, doors shall be of double-pane or triple pane, inert gas-filled, heat-reflective treated glass
- Evaporator fan motors that are < 1 hp and < 460 volts use electronically commutated motors, brushless direct-current motors, or 3-phase motors
- Condenser fan motors < 1 hp use electronically commutated motors, permanent split capacitor-type motors or 3-phase motors

- Antisweat heaters without antisweat heater controls:
limit total door rail, glass and frame heater power draw $< 7.1 \text{ W/ft}^2$ of door opening for walk-in freezers and 3.0 W/ft^2 of door opening for walk-in coolers
- Where antisweat heater controls are provided
reduce the energy use of the antisweat heater as a function of the relative humidity in the air outside the door or of the condensation on the inner glass plane

Site assembled or site constructed walk-ins have identical provisions to pre-manufactured walk-ins.

- Automatic door closers be provided that fully close walk-in doors that have been closed to within 1” of full closure
 - **Exception** – automatic losers are not required for doors > 45” in width or > 7ft in height
- Doorways have strip doors, curtain, spring hinged doors or other approved method of minimizing infiltration when doors are open
- Walls shall be provided with insulation having a thermal resistance of $\geq R-25$, ceilings with insulation having a thermal resistance and doors $\geq R-25$ and doors
 - **Exception** – insulation is not required for glazed portions of doors or at structural members associated with the walls, ceiling or door frame

- Floor of walk-in freezers provided with insulation having a thermal resistance of $\geq R-28$
- Transparent reach-in doors for and windows in opaque walk-in freezer doors provided with triple-pane glass having the interstitial spaces filled with inert gas or provided with heat-reflective treated glass
- Transparent reach-in doors for and windows in opaque walk-in cooler doors be double-pane heat-reflective treated glass having the interstitial space gas filled
- Evaporator fan motors <1 hp and < 460 volts be electronically commutated motors or 3-phase motors
- Condenser fan motors <1 hp in capacity be of the electronically commutated or permanent split capacitor-type or be 3-phase motors
 - **Exception** – fan motors in walk-in coolers and freezers combined in a single enclosure $>3,000$ ft² in floor area are exempt

- Antisweat heaters without antisweat heater controls are provided, have a total door rail, glass and frame heater power draw $< 7.1 \text{ W/ft}^2$ of door opening for walk-in freezers and 3.0 W/ft^2 of door opening for walk-in coolers
- Where antisweat heater controls are provided, they shall reduce the energy use of eth antisweat heater as a function of the relative humidity in the air outside the door or to the condensation on the inner glass plane

Site-assembled or site-constructed refrigerated display cases shall comply with the following:

- Lighting and glass doors controlled by one of the following:
 - Time switch controls to turn off lights during nonbusiness hours. Timed overrides for display case shall turn the lights on for up to 1 hour and automatically time out to turn the lights off
 - Motion sensor controls on each display case section that reduce lighting power by at least 50% within 3 minutes after the area within the sensor range is vacated
- Low-temp. display cases incorporate temp.-based defrost termination control with a time-limit default. The defrost cycle shall terminate first on an upper temp. limit breach and second upon a time limit breach.
- Antisweat heater controls to reduce the energy use of the antisweat heater as a function of the relative humidity in the air outside the door or to the condensation on the inner glass pane

Climate Zones - 2015 IECC

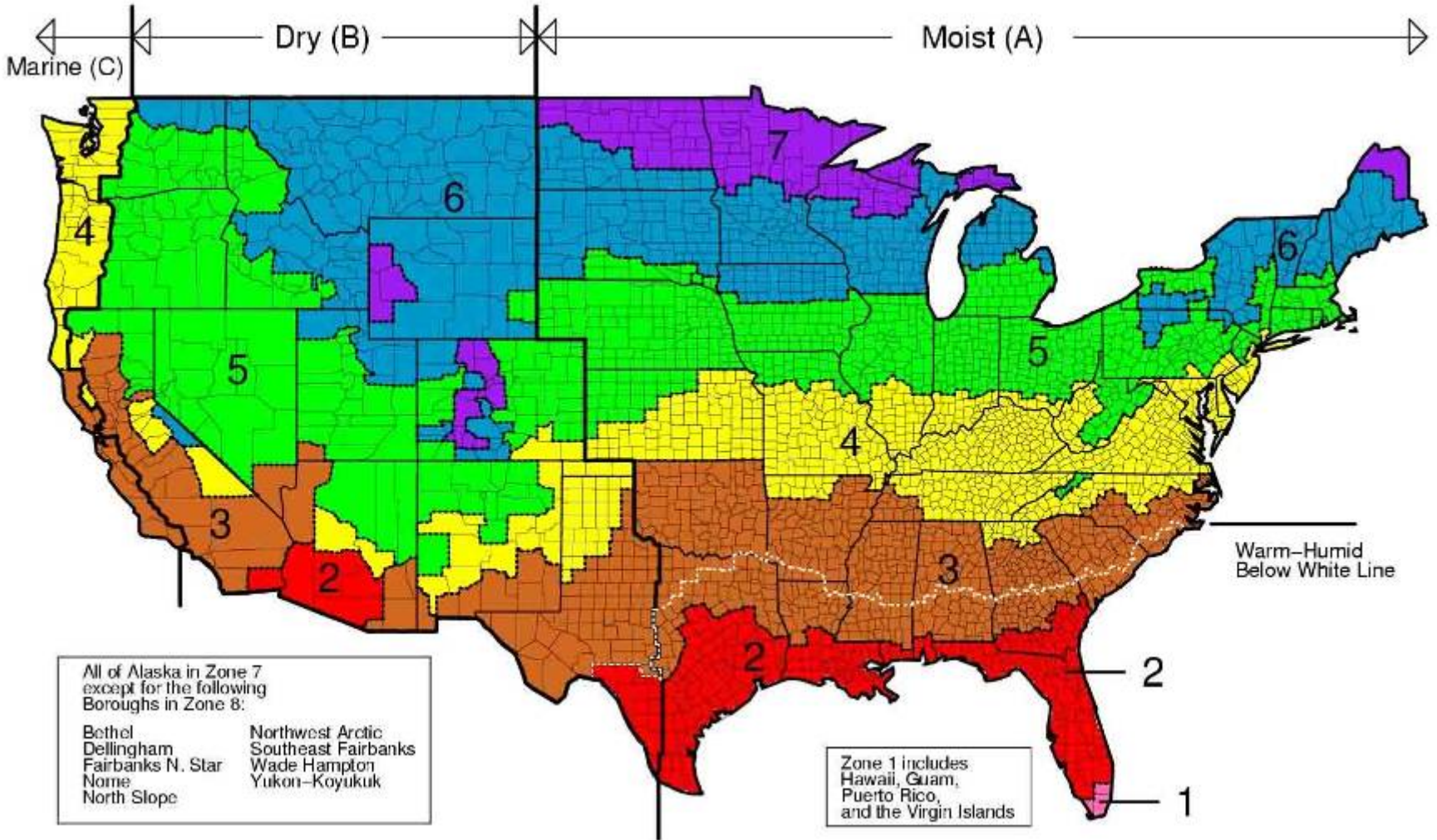

CLIMATE ZONES	ECONOMIZER REQUIREMENT
1A, 1B	No requirement
2A, 2B, 3A, 3B, 3C, 4A, 4B, 4C, 5A, 5B, 5C, 6A, 6B, 7, 8	Economizers on individual DX cooling units $\geq 54,000$ Btu/h ^a
	Economizer (usually central water economizer) on any chilled water cooling unit if total cooling meets table C403.3 limits

Total supply capacity of all fan-cooling units not provided with economizers shall not exceed 20% of the total supply capacity of all fan-cooling units in the building or 300,000 Btu/h, whichever is greater, unless otherwise excepted

Economizers

Section C303.3

Climate Zones (Cooling)	Total Chilled-Water System Capacity < Capacity of Cooling Units with Air Economizers	
	Local Water-cooled Chilled- water Systems	Air-cooled Chilled-water Systems or District Chilled-water Systems
1a	No economizer requirement	No economizer requirement
1b, 2a, 2b	960,000 Btu/h	1,250,000 Btu/h
3a, 3b, 3c, 4a, 4b, 4c	720,000 Btu/h	940,000 Btu/h
5a, 5b, 5c, 6a, 6b, 7, 8	1,320,000 Btu/h	1,720,000 Btu/h

Example: Hotel with guest room chilled water fan coil units totaling 1,500 MBH of cooling capacity in climate zone 5A

- Central water economizer or individual fan coil air economizers required if a water-cooled chiller
- No economizer requirement if all air-cooled chillers or district chilled water source outside of building

Exceptions: (economizers not required)

- ✓ Where $> 25\%$ of air designed to be supplied by the system is to spaces that are designed to be humidified $> 35^{\circ}\text{F}$ dew-point temperature to satisfy process needs
- ✓ Systems that serve residential spaces where system capacity is < 5 times requirement in Table C403.3.1(1)
- ✓ Systems expected to operate < 20 hours/week
- ✓ Where use of outdoor air for cooling will affect supermarket open refrigerated casework systems
- ✓ Where cooling efficiency meets or exceeds efficiency requirements in Table C403.3(2)

- Chilled-water cooling systems that are passive (without a fan) or use induction where the total chilled water system capacity less the capacity of fan units with air economizers is less than the minimum specified in Table C403.3(1)
- Systems that include a heat recovery system in accordance with Section 403.4.7

Trade-off high cooling efficiency for economizer

Table C403.3(2)

CLIMATE ZONES	COOLING EQUIPMENT PERFORMANCE IMPROVEMENT (EER OR IPLV)
2B	10% Efficiency Improvement
3B	15% Efficiency Improvement
4B	20% Efficiency Improvement

- Systems to be integrated with the mechanical cooling system and capable of providing partial cooling even where additional mechanical cooling is required to provide the remainder of the cooling load
- Controls shall not be capable of creating a false load in the mechanical cooling systems by limiting or disabling the economizer or any other means, such as hot gas bypass, except at the lowest stage of mechanical cooling

Units that include an air economizer to comply with the following:

- Unit controls have the mechanical cooling capacity control interlocked with the air economizer controls such that the outdoor air damper is at the 100% open position when mechanical cooling is on and the outdoor air damper does not begin to close to prevent coil freezing due to minimum compressor run time until the leaving air temp. $< 45^{\circ}\text{F}$
- Direct expansion (DX) units that control $\geq 75,000$ Btu/h of rated capacity of the capacity of the mechanical cooling directly based on occupied space temp. shall have not fewer than two stages of mechanical cooling capacity
- Other DX units including those that control space temp. by modulating the airflow to the space be in accordance with Table C403.3.1

HVAC system design and economizer controls shall be such that economizer operation does not increase building heating energy use during normal operations

Exception: Economizers on variable air volume (VAV) systems that cause zone level heating to increase due to a reduction in supply air temperature

Capable of modulating outdoor air and return air dampers to provide up to 100% of design supply air quantity as outdoor air for cooling

Economizer dampers to be capable of being sequenced with mechanical cooling equipment and not be controlled by only mixed air temperature

Exception:

- ✓ Can use mixed air temperature limit control for systems controlled from space temperature

Example: single-zone systems

- ✓ Air economizers to be capable of automatically reducing outdoor air intake to design minimum outdoor air quantity when outdoor air intake will no longer reduce cooling energy usage
- ✓ High-limit shutoff control types to be chosen from Table C403.3.1.1.3(1) for specific climates
- ✓ Specifications for high-limit shutoff control type settings per Table C403.3.1.1.3(2)

- ✓ Systems to be capable of relieving excess outdoor air during air economizer operation to prevent over-pressurizing the building
- ✓ Relief air outlet to be located to avoid recirculation into the building

Return, exhaust/relief and outdoor air dampers used in economizers shall comply with Section C403.2.4.3 (Shut Off Dampers)

Capable of cooling supply air by indirect evaporation and provide up to 100% of expected system cooling load at outdoor air temperatures < 50°F dry bulb/45°F wet bulb

Exceptions:

- Systems primarily serving computer rooms in which 100% of expected system cooling load at 40°F dry bulb/35°F wet bulb is met with evaporative water economizers
- Systems primarily serving computer rooms with dry cooler water economizers which satisfy 100% of the expected system cooling load at 35°F dry bulb
- Systems where dehumidification requirements cannot be met using outdoor air temps of 50°F dry bulb/45°F web bulb and where 100% of expected system cooling load at 45°F dry bulb/40°F wet bulb is met with evaporative water economizers

Water-side Economizers

Section C403.3.4.2 Maximum Pressure Drop

Precooling coil and water-to-water heat exchangers used as part of a water economizer system to have either a:

- water side pressure drop < 15 feet of water **OR**
- secondary loop created so that the coil or heat exchanger pressure drop is not seen by the circulating pumps when the system is in normal cooling (non-economizer) mode

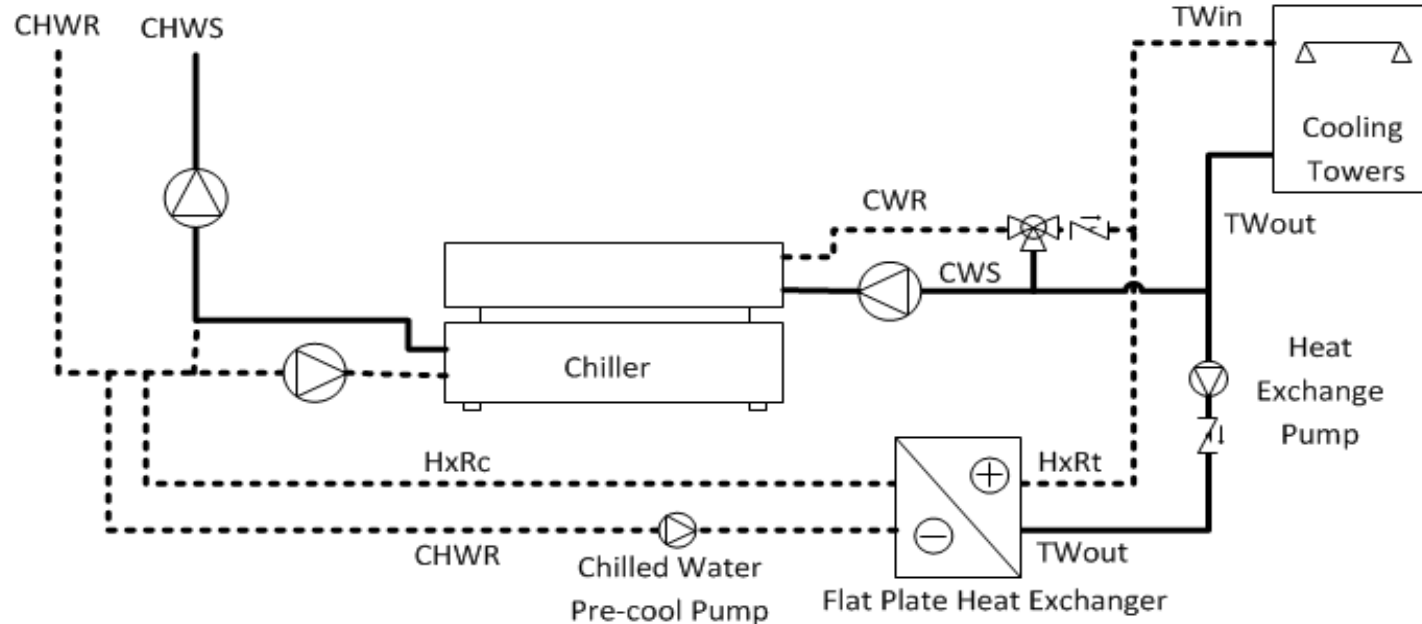

Systems Include:

- ✓ Packaged VAV reheat
- ✓ Built-up VAV reheat
- ✓ Built-up single-fan, dual-duct VAV
- ✓ Built-up or packaged dual-fan, dual-duct VAV
- ✓ Four-pipe fan coil system with central plant
- ✓ Water Source heat pump with central plant
- ✓ Any other multiple-zone system
- ✓ Hydronic space heating and cooling system

Each cooling system listed in Table C403.4.1.1 be designed to vary the indoor fan airflow as a function of load and comply with the following:

- Direct expansion (DX) and chilled water cooling units that control capacity of mechanical cooling directly based on space temp to have not fewer than 2 stages of fan control
 - Low or minimum speed \leq 66% full speed
 - fan to draw \leq 40% of fan power at full fan speed
 - Used during period of low cooling load and ventilation-only operation
- Other units including DX cooling and chilled water that control the space temp. by modulating the airflow to the space have modulation fan control (usually a variable speed drive)
 - Minimum speed \leq 50% of full speed
 - Fan to draw \leq 30% of fan power at full fan speed
 - Low or minimum speed used during period of low cooling load and ventilation-only operation

Units that include an airside economizer in accordance with Section C403.3 to have not fewer than two speeds of fan control during economizer operation

Exceptions:

- Modulating fan control is not required for chilled water and evaporative cooling units with fan motors < 1 hp where the units are not used to provide ventilation air and the indoor fan cycles with the load
- Where the volume of outdoor air required to comply with the ventilation requirements of IMC at low speed exceeds the air that would be delivered at the speed defined in Section C403.4.1
 - Minimum speed to be selected to provide the required ventilation air

Variable Air Volume Fan Control

Section C403.4.2

Individual VAV fans with motors ≥ 7.5 hp must be:

- ✓ Driven by a mechanical or electrical variable speed drive **OR**
- ✓ Driven by a vane-axial fan with variable-pitch blades **OR**
- ✓ Have controls or devices to result in fan motor demand $\leq 30\%$ of their design wattage at 50% of design airflow

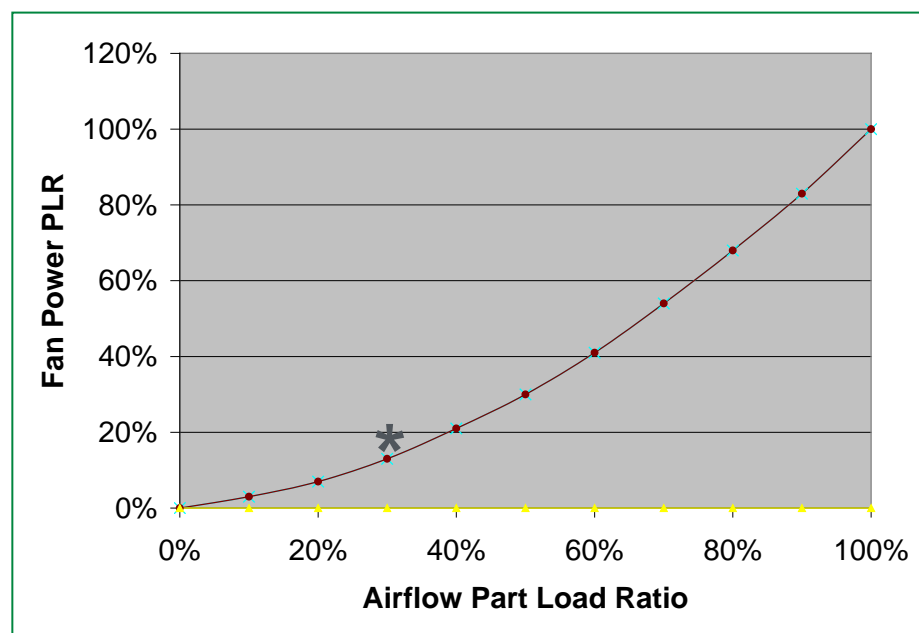

- ✓ Sensors used to control VAV fans
 - Placed so that the controller setpoint is ≤ 1.2 inches w.c.
- ✓ Sensors installed downstream of major duct splits
 - At least one sensor to be located on each major branch so that static pressure can be maintained in each branch

- Systems with direct digital control of individual reporting to the central control panel
 - Static pressure set point to be reset based on the zone requiring the most pressure (i.e., the set point is reset lower until one zone damper is nearly wide open)
 - Direct digital controls capable of monitoring zone damper positions or have an alternative method of indication the need for static pressure capable of all of the following:
 - Automatically detecting any zone that excessively drives the reset logic
 - Generating an alarm to the system operational location
 - Allowing an operator to readily remove ≥ 1 zones from the reset algorithm

Hydronic System Controls

Section C403.4.2

- ✓ Limit reheat/recool of fluids
- ✓ Multiple boiler heating plants must include automatic controls capable of sequencing operation of the boilers
- ✓ Single boilers $> 500,000$ Btu/h input design capacity must include multi-staged or modulating burner



Hydronic Systems

Section C403.4.2

3-Pipe System – not allowed

- ✓ Can't use a common return

2-Pipe Changeover System

- ✓ Dead band between changeover $\geq 15^{\circ}\text{F}$ outside temperature

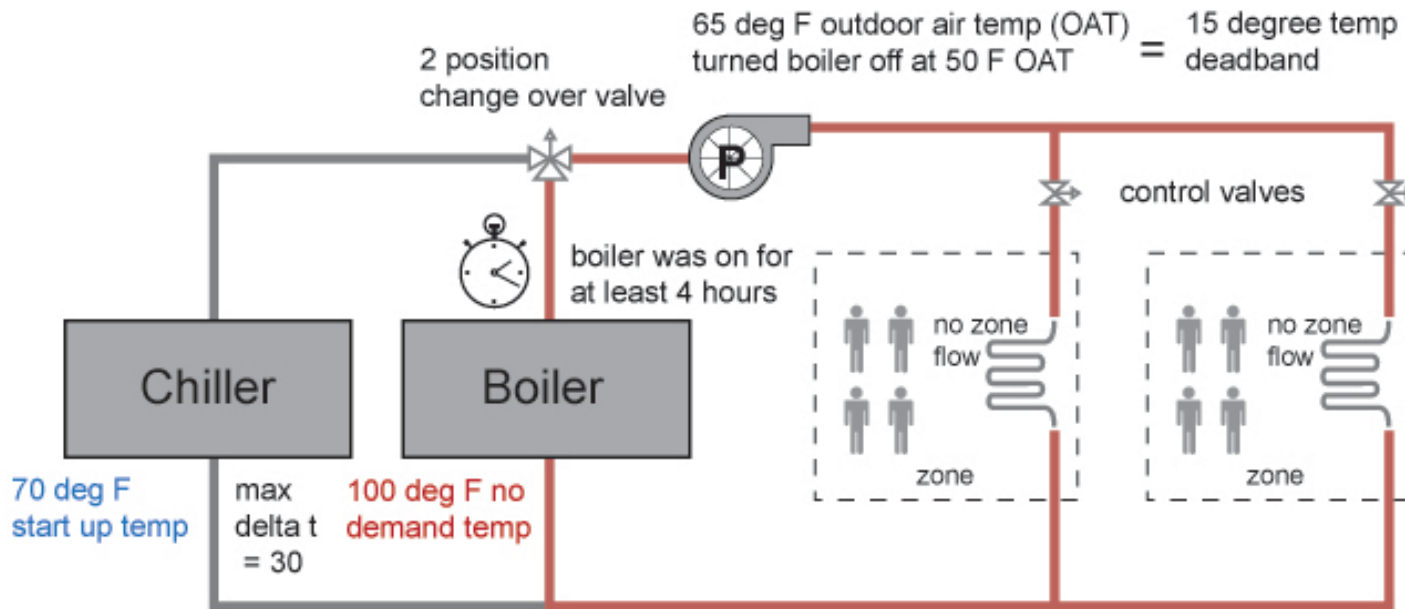

Diagram Courtesy of Ken Baker

Hydronic Water Loop Heat Pump Systems

Section C403.4.2.3

Temperature dead band of at least 20°F (C403.4.2.3.1)

✓ Exception:

- Where system loop temp optimization controller is installed and can determine the most efficient operating temp based on real time conditions of demand and capacity

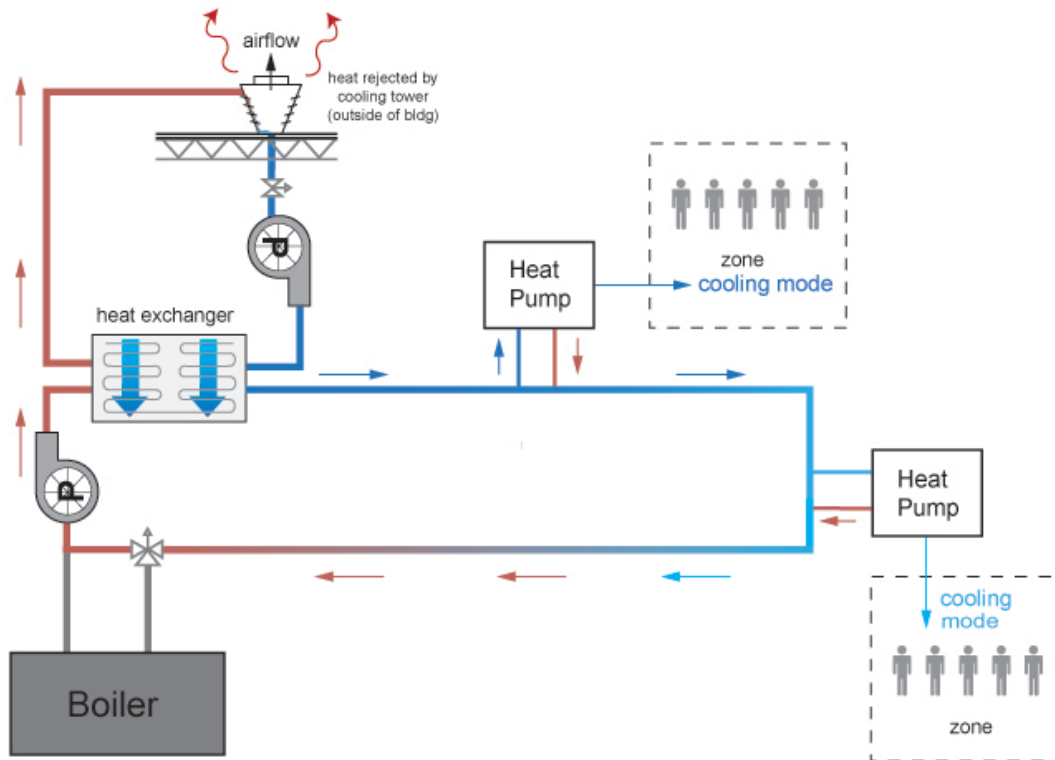

Diagram Courtesy of Ken Baker

Example:

Heat rejection off below
75°F loop temperature.

Boiler off above 55°F loop
temperature

$$75^{\circ}\text{F} - 55^{\circ}\text{F} =$$

20°F dead band

Heat rejection equipment in **Climate Zones 3 and 4** (C403.4.2.3.2)

- ✓ Closed-circuit cooling tower used directly in heat pump loop
 - Install either automatic valve to bypass all but a minimal flow of water around tower OR lower leakage positive closure dampers to be provided
- ✓ Open-circuit tower used directly in heat pump loop
 - Install automatic valve to bypass all heat pump water flow around tower
- ✓ Open- or closed-circuit used in conjunction with separate heat exchanger to isolate cooling tower from heat pump loop
 - Heat loss controlled by shutting down the circulation pump on cooling tower loop

Heat rejection equipment in **Climate Zones 5 - 8**

- ✓ Open- or closed-circuit cooling tower used
 - Must have a separate heat exchanger to isolate cooling tower from heat pump loop
 - Heat loss controlled by shutting down circulation pump on cooling tower loop and providing an automatic valve to stop flow of fluid

Hydronic Water Loop Heat Pump Systems

Section C403.4.2.3 – cont'd.

Two position valve (C403.4.2.3.3)

- ✓ Required on each hydronic heat pump where total system pump power > 10 hp

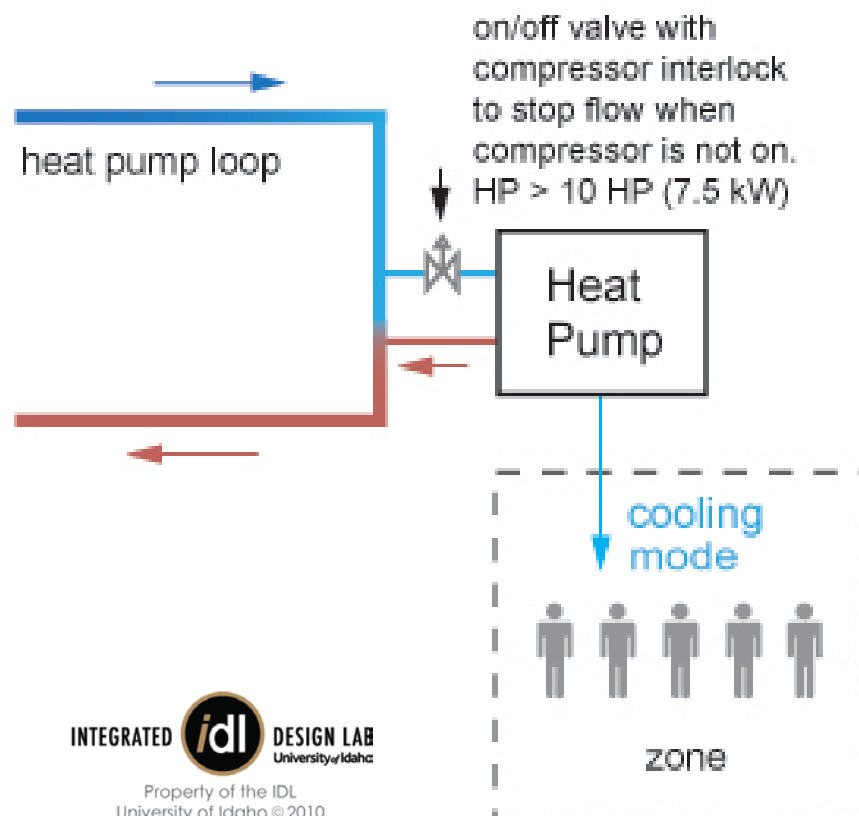

Hydronic System Part Load Control

Section C403.4.2.4

System $\geq 500,000$ Btu/h heating or cooling must include

✓ Temperature reset and variable flow

- Automatic resets for supply water temperature by at least 25% of design supply-to-return temperature differences **and**
- Automatic vary fluid flow if a combined motor capacity ≥ 10 hp with ≥ 3 control valves or other devices:

Must reduce system design flow rate by $\geq 50\%$ by designed valves or pumps that modulate flow:

- Modulating valves or VSD on pumps,
- Valves that step open and close OR
- Sequencing pumps or valves turn on and off as function of load
- Automatic vary pump flow on chilled-water system and heat rejection loops serving cooled unitary air conditioners with a combined pumping motor capacity ≥ 10 hp by reducing pump design flow $\geq 50\%$
 - Utilizing adjustable speed drives on pump OR
 - Multiple-staged pumps \geq half of total pump hp is capable of being automatically turned off
 - Pump flow rate to be controlled to maintain one control valve nearly wide open Or to satisfy the minimum differential pressure

Hydronic System Part Load Control

Section C403.4.2.4

Exceptions:

- Supply-water temp. reset for chilled-water systems supplied by off-site district chilled water or chilled water from ice storage systems
- Minimum flow rates other than 50% as required by the equipment manufacturer for proper operation of equipment where using flow bypass or end-of-line 3-way valves
- Variable pump flow on dedicated equipment circulation pumps where configured in primary/secondary design to provide the minimum flow requirements of the equipment manufacturer for proper operation of equipment

Example:

Variable flow secondary pump required if 10 hp or more

No VSD required on primary chiller pump where each chiller has a dedicated pump designed at minimum flow.

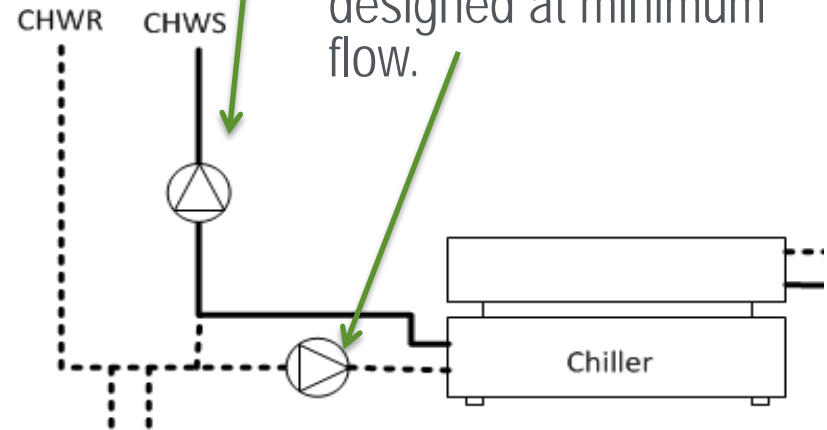

Boiler systems with design input $\geq 1,000,000$ Btu/h to comply with turndown ratio specified in Table C403.4.2.5

**TABLE C403.4.2.5
BOILER TURNDOWN**

BOILER SYSTEM DESIGN INPUT (Btu/h)	MINIMUM TURNDOWN RATIO
$\geq 1,000,000$ and less than or equal to 5,000,000	3 to 1
$> 5,000,000$ and less than or equal to 10,000,000	4 to 1
$> 10,000,000$	5 to 1

For SI: 1 British thermal unit per hour = 0.2931 W.

System turndown requirement must be met through the use of

- multiple single input boilers **OR**
- ≥ 1 modulating boilers **OR**
- combination of single input and modulating boilers

Pump Isolation

Section C403.4.2.6

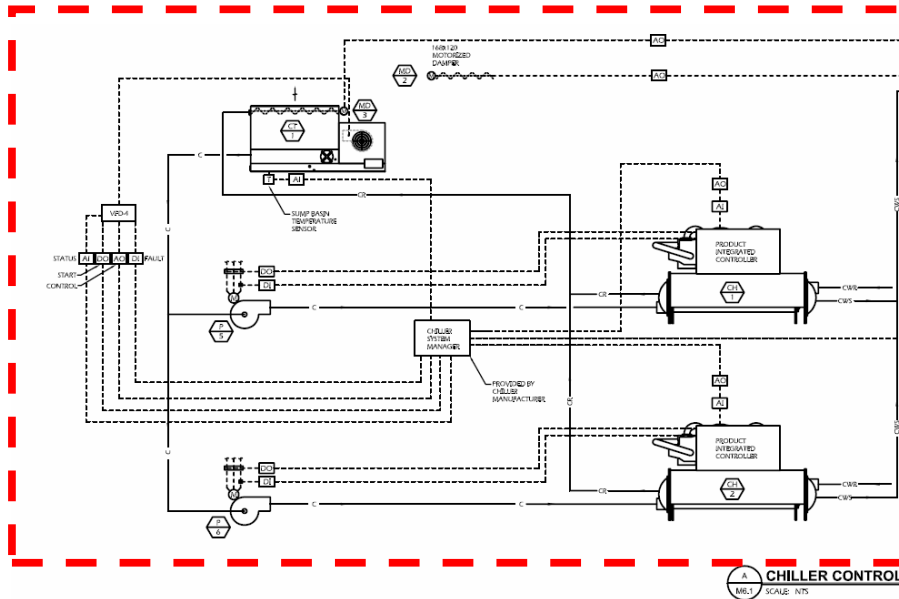

Multiple chiller chilled water plants

- ✓ Capability to reduce flow through the chiller automatically when chiller is shut down
- ✓ Chillers piped in series considered one chiller

What to look for:

Separate pumps for each boiler or chiller with check valves, OR

A variable flow pump with isolation valves for each boiler or chiller

Multiple boiler plants

- ✓ Capability to reduce flow through the boiler automatically when boiler is shut down

Heat Rejection Equipment

Section C403.4.3

Each tower fan powered by a motor ≥ 7.5 hp must include variable speed or two speed fan

- ✓ Have controls to automatically change the fan speed to control the leaving fluid temperature or condensing temperature/pressure of the heat rejection device
- ✓ **Exception:**
 - Factory-installed heat rejection devices within condensers and chillers tested and rated in accordance with Tables C403.2.3(6) and C403.2.3(7)



- Air-cooled condensers, dry coolers, open-circuit cooling towers, closes-circuit cooling towers, and evaporative condensers used for comfort cooling applications must comply with Section C403.4.3
 - **Exception**: heat rejection devices where energy usage is included in the equipment efficiency ratings listed in Tables C403.2.3(6) and C403.2.3(7)

Must have the capability to

- Operate at $\leq 2/3$ of full speed
- Controls that automatically change fan speed to control the leaving fluid temp. or condensing temp./pressure of the heat rejection device

Exception:

- Condenser fans serving multiple refrigerant circuits
- Condenser fans serving flooded condensers
- Installations located in **Climate Zones 1 and 2**

Multiple-cell heat rejection equipment with variable speed fan drives to be controlled in both manners:

- Operate the maximum number of fans allowed that comply with manufacturer's requirements for all system components
- So all fans can operate at the same fan speed required for the instantaneous cooling duty, as opposed to staged (on/off) operation

Minimum fan speed must be the minimum allowable speed of the fan drive system in accordance with manufacturer's recommendations

Combined rated capacity > 1,100 gpm at 95°F condenser water return, 85°F condenser water supply, 75°F outdoor air wet-bulb temperature must meet the energy efficiency requirement for axial fan open-circuit cooling towers listed in Table C403.2.3(3)

Exception:

Centrifugal open-circuit cooling towers that are designed with inlet or discharge ducts or require or require external sound attenuation

Open-circuit cooling towers used on water-cooled chiller system that are configured with multiple or variable-speed condenser water pumps

- Designed that all open circuit cooling tower cells can be run in parallel with the larger of
 - the flow that is produced by the smallest pump at its minimum expected flow rate OR
 - 50% of the design flow for the cell

- ✓ Must be variable air volume (VAV) systems
- ✓ VAV systems must be designed and capable of being controlled to reduce the primary air supply to each zone before reheat, recool, or mixing take place
- ✓ Maximum airflow in reheat, recool, or mixing—one of:
 - 30% of the maximum supply air to each zone
 - ≤ 300 cfm where the maximum flow rate is $<10\%$ of total fan system design supply airflow rate
 - Minimum ventilation requirements from Chapter 4 of the IMC
 - Any higher rate that can be demonstrated to reduce overall system annual energy use by offsetting reheat/recool energy losses through reduction in outdoor air intake for the system, as approved by code official
 - Airflow rate required to comply with applicable codes or accreditation standards, such as pressure relationships or minimum air change rates

Exceptions from VAV control (individual zones or systems):

- ✓ Where $\geq 75\%$ of reheat energy comes from site-recovered or site-solar energy source
- ✓ Zones with special humidity requirements
- ✓ Zones with ≤ 300 cfm peak supply and flow rate is $< 10\%$ of total fan system supply airflow rate
- ✓ Zones where reheated, recooled or mixed air volume $<$ minimum ventilation requirements (Chapter 4 of IMC)
- ✓ Systems with controls capable of preventing reheating, recooling, mixing or simultaneous supply of air previously heated or cooled

Single Duct VAV Systems, Terminal Devices

Section C403.4.4.1

Single duct VAV systems to use terminal devices capable of reducing the supply of primary supply air before reheating or recooling takes place



Dual Duct and Mixing VAV Systems, Terminal Devices

Section C403.4.4.2

Systems with one warm air duct and one cool air duct to use terminal devices capable of reducing flow from one duct to a minimum before mixing of air from the other duct takes place

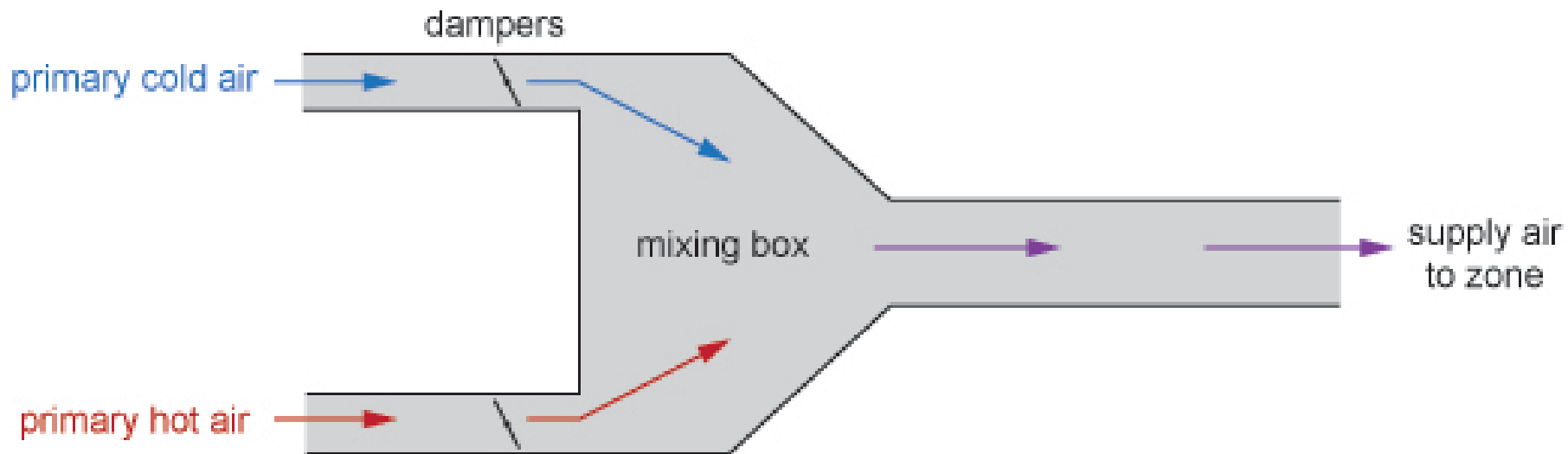

Single Fan Dual Duct and Mixing VAV Systems, Economizers

Section C403.4.4.3

Individual dual duct or mixing reheating and cooling systems with a single fan and with total capacities $> 90,000$ Btu/h (7.5 tons) should not have economizers

- Motors for fan $\geq 1/12$ hp and < 1 hp shall be electronically commutated motors OR have a minimum motor efficiency of 70% rated in accordance with DOE 10 CFR 431
- Motors must have the means to adjust motor speed for either balancing or remote control
- The use of belt-driven fans with sheave adjustments for airflow balancing instead of a varying motor speed is permitted

Exceptions:

- Motors in the airstream within fan coils and terminal units that only provide heating to the space served
- Motors in space-conditioning equipment that comply with Section C403.2.3 or C403.2.12
- Motors that comply with Section C405.8

Supply-Air Temperature Reset Controls

Section C403.4.4.5

Multiple zone HVAC systems to have controls to automatically reset supply-air temperature in response to building loads or outdoor air temperature

Controls to be capable of resetting supply air temperature at least 25% of difference between design supply-air temperature and design room air temperature

Exceptions:

- ✓ Systems that prevent reheating, recooling or mixing of heated and cooled supply air
- ✓ 75% of energy for reheating is from site-recovered or site solar energy sources
- ✓ Zones with peak supply air quantities of ≤ 300 cfm

Multiple-zone VAV System Ventilation Optimization Control

Section C403.4.4.6

- Multiple-zone VAV systems with direct digital control of individual zone boxes reporting to central control panel
 - Automatic controls configured to reduce outdoor air intake flow below design rates in response to changes in system ventilation efficiency (E_v) as defined by IMC
- **Exceptions:**
 - VAV systems with zonal transfer fans that recirculate air from other zones without directly mixing it with outdoor air, dual-duct dual-fan VAV systems, and VAV systems with fan-powered terminal units
 - Systems having exhaust air energy recovery complying with Section C403.2.7
 - Systems where total design exhaust airflow is $> 70\%$ of total design outdoor air intake flow requirements

Heat Recovery for Service Hot Water Heating

Section C403.4.5

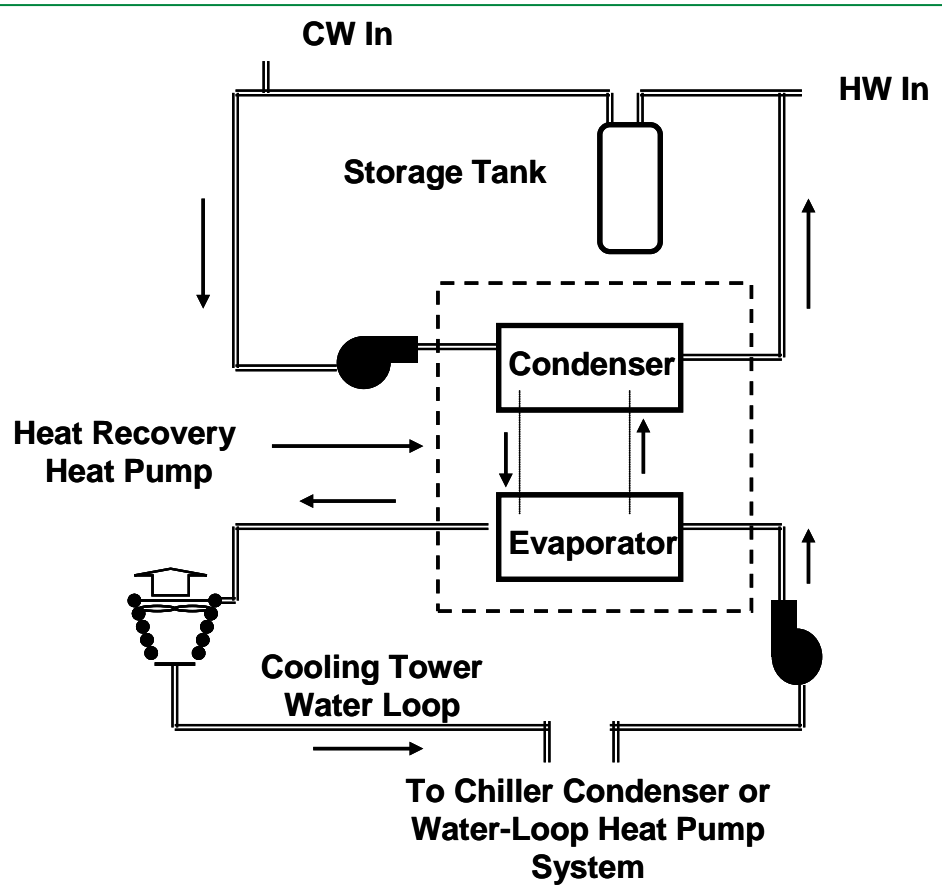

Condenser heat recovery required for heating/reheating of SWH provided:

- ✓ Facility operates 24 hours/day
- ✓ Total installed heat capacity of the heat rejection of water-cooled systems $>6,000,000$ Btu/hr
- ✓ Design SWH load $>1,000,000$ Btu/hr

Capacity to provide the smaller of

- ✓ 60% of peak heat rejection load at design conditions OR
- ✓ Preheating to raise peak SWH to 85°F

Exceptions:

- ✓ Recovered heat is used for space heating or when SWH is provided by renewables or site recovered energy sources

Cooling systems can't use unless system designed with

- ✓ multiple steps of unloading **OR**
- ✓ Continuous capacity modulation

Capacity limited per Table C403.4.6 as limited by Section C403.3.1

Rated Capacity	Maximum Hot Gas Bypass Capacity (% of total capacity)
$\leq 240,000$ Btu/h	50%
$> 240,000$ Btu/h	25%

- Display cases, walk-in coolers or walk-in freezers served by remote compressors and remote condensers not located in a condensing unit must comply with Sections C403.5.1 and C403.5.2
- Exception: Systems where the working fluid in the refrigeration cycle goes through both subcritical and supercritical states (transcritical) or that use ammonia refrigerant

Fan-Powered Condensers

- Design saturated condensing temperatures for air-cooled condenser not to exceed
 - design dry-bulb temp. plus 10°F for low-temp. refrigeration systems
 - Design dry-bulb temp. plus 15°F for medium temp. refrigeration systems where saturated condensing temp. for blend refrigerants should be determined using the average of liquid vapor temps. as converted from the condenser drain pressure
- Condenser fan motors < 1 hp use electronically commutated motors, permanent split-capacitor-type motors or 3-phase motors

Condensers Serving Refrigeration Systems

Section C403.5.1 – Cont'd.

- Air-cooled condensers, evaporatively cooled condensers, air- or water-cooled fluid coolers or cooling towers must reduce fan motor demand $\leq 30\%$ of design wattage at 50% of design air volume, and incorporate one of the following continuous variable speed fan control approaches:
 - Control for air-cooled condensers must use variable setpoint control logic to reset the condensing temp. setpoint in response to ambient dry-bulb temp.
 - Control for evaporatively cooled condensers must use variable setpoint control logic to reset the condensing temp. setpoint in response to ambient wet-bulb temp.
- Multiple fan condensers to be controlled in unison
- Minimum condensing temp. setpoint $\leq 70^{\circ}\text{F}$

- Compressors and multiple-compressor system suction groups must include control systems that use floating suction pressure control logic to reset the target suction pressure temp. based on the temp. requirements of the attached refrigeration display cases or walk-ins:

Exception: controls are not required for:

- Single-compressor system that do not have variable capacity capability
- Suction groups that have:
 - a design saturated suction temp. of $\geq 30^{\circ}\text{F}$,
 - comprise the high stage of a two-stage or cascade system OR
 - Primarily serve chillers for secondary cooling fluids

- Liquid subcooling must be provided for all low-temp. compressor systems with a design cooling capacity $\geq 100,000$ Btu/hr with a design-saturated suction temp. $\leq -10^{\circ}\text{F}$
 - Sub-cooled liquid temp. to be controlled at max. temp. setpoint of 50°F at the exit of the subcooler using either compressor economizer ports or a separate compressor suction group operating at a saturated suction temp. $\geq 18^{\circ}\text{F}$
 - Insulation for liquid lines with a fluid operating temp. $< 60^{\circ}\text{F}$ must comply with Table C403.2.10
- Compressors that incorporate internal or external crankcase heaters must provide a means to cycle the heaters off during compressor operation

Table C404.2 Minimum Performance of Water-Heating Equipment

✓ Water Heater Types Covered

- Electric Storage
- Gas and Oil Storage
- Instantaneous Water Heaters – Gas and Oil
- Hot water boilers – gas and oil
- Pool heaters
- Unfired storage tanks

Heat Traps (C404.3)

Piping Insulation (C404.4)

Efficient Piping (C404.5)

Circulation & Temperature Maintenance (C404.6)

Demand Recirculation (C404.7)

Drain Heat Recovery (C404.8)

Pools and Spas (C404.9)

Portable Spas (C404.10)

SWH Commissioning (C404.11)



- Water-heating equipment and hot water storage tanks must meet Table C404.2
- Efficiency verified through data furnished by manufacturer of equipment or through certification under an approved certification program
- Water-heating equipment intended to be used to provide space heating must meet Table C404.2

- Gas-fired equipment installed in new buildings
- Single piece serves entire building with input rating $\geq 1,000,000$ Btu/h
 - Thermal efficiency $\geq 90\%$
- Multiple pieces with combined input rating $\geq 1,000,000$ Btu/h
 - Combined input-capacity-weighted-average thermal efficiency $\geq 90\%$

Exceptions:

- 25% of annual SWH requirement is provided by site-solar or site-recovered energy
- Input rating of water heaters installed in individual dwelling units
- Individual units with input rating $\leq 100,000$ Btu/h not considered part of building SWH equipment

Equipment not supplied with integral heat traps and serving noncirculating systems must have heat traps on the supply and discharge piping associated with the equipment



Insulation of Piping

Section C404.4

- Piping from water heater to termination of heated water fixture supply pipe (all recirculation piping) to be insulated per Table C403.2.10
- Both inlet and outlet piping of storage water heater or heated water storage tank
 - Piping to a heat trap or first 8 ft. of piping, whichever is less
- Piping that is heat traced per Table C403.2.10 or heat trace manufacturer instructions
- Tubular piping insulation installed in accordance with insulation manufacturer's instructions
- Insulation to be continuous
 - Except where piping passes through a framing member
- Minimum insulation thickness not to supersede any greater insulation thickness requirements necessary for the protection of piping from freezing temps. or personnel against external surface temps. on the insulation

Exceptions:

- Tubing from the connection at the termination of the fixture supply piping to a plumbing fixture or plumbing appliance
- Valves, pumps, strainers and threaded unions in piping that is ≤ 1 " in nominal diameter
- Piping from user-controlled shower and bath mixing valves to the water outlets
- Cold-water piping of demand recirculation water system
- Tubing from hot drinking-water heating unit to the water outlet
- Piping at locations where a vertical support of the piping is installed
- Piping surrounded by building insulation with a thermal resistance $\geq R-3$

For piping from the *nearest source of heated water* (from the water heater or from the recirculation or trace heated loop) to fixture requires either maximum pipe length (C404.5.1) or maximum pipe volume (C404.5.2) and has maximum flow rated by size

- Flow rate through 1/4" piping should be ≤ 0.5 gpm
- Flow rate through 5/16" piping should be ≤ 1.0 gpm
- Flow rate through 3/8" piping should be ≤ 1.5 gpm

Intent is to reduce wasting previously-heated water that has cooled in pipes that do not require insulation

Maximum allowed piping length from nearest source of heated water to termination of the fixture supply pipe:

Where piping contains more than one size, the largest size of pipe within the piping shall be used for determining the max. allowable length of piping in Table C404.5.1

- Public lavatory faucet, use “Public Lavatory faucets” column in Table C404.5.1
- All other plumbing fixtures and plumbing appliances use “Other fixtures and appliances” column in Table C404.5.1

- Water heaters, circulating water systems, and heat trace temp. maintenance systems to be considered sources of heated water
- Volume from the nearest source of heated water to the termination of the fixture supply pipe as follows:
 - Public lavatory facet: ≤ 2 ounces
 - Other plumbing fixtures or plumbing appliances: ≤ 0.5 gallon

- Volume to be the sum of the internal volumes of pipe, fittings, valves, meters and manifolds between the nearest source of heated water and the termination of the fixture supply pipe
- Volume determined from the “Volume” column in Table
- Volume contained with fixture shutoff valves, within flexible water supply connectors to a fixture fitting and within a fixture fitting should not be included in the water volume determination
- Heated water supplied by recirculating system or heat-traced piping, the volume should include the portion of the fitting on the branch pipe that supplies water to the fixture

Heated-water Circulating and Temperature Maintenance Systems

Section C404.6

- Circulation Systems
 - Controlled pump(s) required
 - Demand control required (see C404.7)
 - Gravity and thermosyphon not allowed
- Heat Trace Systems
 - Energy input adjusted to maintain temperature
 - Timed or demand automatic controls
- Controls for Hot Water Storage Tank Pumps
 - Automatic controls limit pump operation to no more than 5 minutes after heater operation

- Systems with ≥ 1 recirculation pumps that pump water from a heated-water supply pipe back to the heated-water source through a cold-water supply pipe must be a demand recirculation water system
- Pumps to have controls that:
 - Start pump upon receiving a signal from the action of a user of a fixture or sensing the flow of hot or tempered water to a fixture fitting or appliance
 - Limit the temp. of water entering the cold-water piping (used as a recirculation return) to 104°F

- Must comply with CSA B55.2
- Potable water-side pressure loss < 10 psi at maximum design flow
- Group R occupancies, units must meet efficiency in accordance with CSA B55.1

Note that this provision does not require the use of drain water heat recovery units; it just specifies their performance if used

Energy Consumption of Pools and Permanent Spas

Section C404.9 Mandatory

Heaters (C404.9.1)

- ✓ Readily accessible on-off switch, that is an integral part of heater, mounted on the exterior of heater or external to within 3 feet of heater
- ✓ Switch should not change the setting of the heater thermostat
- ✓ Switches to be in addition to a circuit breaker for the power to the heater
- ✓ Natural gas or LPG fired pool heaters will not have continuously burning pilot lights

Time switches or other control method (C404.9.2)

- ✓ Automatic controls required to control heaters and pumps on a preset schedule
- ✓ **Exceptions:**
 - Where public health standards require 24 hour operation
 - Where pumps are required to operate solar and waste heat recovery pool heating systems

Note: heaters, pumps and motors with built-in timers meet this requirement

Covers

Section C404.9.3

Outdoor heated pools and outdoor permanent spas required to have a cover

- ✓ Cover must be vapor-retardant
- ✓ Or other approved vapor-retardant means



Exception:

- ✓ Pools deriving > 70% of operating season energy for heating from site-recovered or solar energy

- ✓ Prior to passing final mechanical and plumbing inspection
 - Registered design profession to provide evidence of commissioning and completion
- ✓ Construction document notes to clearly indicate provisions for commissioning and completion requirements
 - Permitted to refer to specifications
- ✓ Copies of all documents to be provided to the owner and made available to code official upon request

Mechanical Systems Commissioning and Completion Requirements

Section C408.2 Exceptions

- ✓ These systems are exempt from commissioning requirements
 - In buildings where total mechanical equipment capacity is < 480,000 Btu/h (40 tons) cooling capacity **and** < 600,000 Btu/h combined service water heating and space-heating capacity
 - Included in Section C403.3 that serve individual dwelling units and sleeping units

- ✓ Developed by registered design professional or agency and include:
 - ✓ Narrative description of activities to be accomplished during each phase of commissioning
 - ✓ Including personnel who will do each activity
 - ✓ Listing of specific equipment, appliances or systems to be tested and description of tests to be performed
 - ✓ Functions to be tested, including, but not limited to calibrations and economizer controls
 - ✓ Conditions under which test will be performed
 - ✓ At a minimum, testing will affirm winter and summer design conditions and full outside air conditions
 - ✓ Measurable criteria for performance

- ✓ HVAC systems balanced per generally accepted engineering standards
- ✓ Air and water flow rates measured and adjusted to deliver final flow rates within tolerances in product specifications
- ✓ Test and balance activities to include air system and hydronic system balancing

- ✓ Each supply air outlet and zone terminal device equipped with means for air balancing per Chapter 6 of the IMC
- ✓ No discharge dampers used for air-system balancing on constant volume fans and variable volume fans with motors ≥ 10 hp
- ✓ Air systems balanced in a manner to first minimize throttling losses, then, for fans with system power > 1 hp, fan speed adjusted to meet design flow conditions

Exception – fans with motors ≤ 1 hp are not required to have a means for air balancing

- ✓ Individual hydronic heating and cooling coils equipped with means for balancing and measuring flow
- ✓ Hydronic systems proportionately balanced in a manner to first minimize throttling losses, then pump impeller to be trimmed or pump speed to be adjusted to meet design flow conditions
- ✓ Each hydronic system to have either capability to measure pressure across the pump, or test ports at each side of each pump

Exceptions with a means for balancing or measuring flow:

- ✓ Pumps with pump motors ≤ 5 hp
- ✓ Where throttling results in $\leq 5\%$ of nameplate hp draw above that required if the impeller were trimmed

- ✓ To demonstrate the installation and operation of components, systems, and system-to-system interfacing relationships in accordance with approved plans and specifications, such that operation, function, and maintenance serviceability for each of the commissioned systems is confirmed
- ✓ Testing to include all modes and sequence of operation, including under full-load, part-load and the following emergency conditions:
 - ✓ All modes as described in the sequence of operation
 - ✓ Redundant or automatic back-up mode
 - ✓ Performance of alarms, and
 - ✓ Mode of operation upon a lost off power and restoration of power

Exception – unitary or packaged HVAC equipment listed in Tables C403.2.3(1) through C403.2.3(3) that don't require supply air economizers

- ✓ HVAC and SWH control systems to be tested to document that control devices, components, equipment, and systems are calibrated, adjusted and operate in accordance with approved plans and specifications
- ✓ Sequences of operation to be functionally tested to document they operate in accordance with approved plans and specifications

- ✓ Air economizers to undergo a functional test to determine they operate in accordance with manufacturer's specifications

- ✓ Registered design professional or approved agency to complete, certify, and submit to the building owner or owner's authorized agent
- ✓ Report to be organized with mechanical and service hot water findings in separate sections to allow independent review. Report to be identified as "Preliminary Commissioning Report" and will identify:
 - ✓ Itemization of deficiencies found during testing that haven't been corrected at the time of report preparation
 - ✓ Deferred tests that can't be performed at the time of report preparation due to climatic conditions
 - ✓ Climatic conditions required for performance of deferred tests

Preliminary Commissioning Report

Sections C408.2.4.1, C408.2.4.2 Acceptance and Copy of Report

- ✓ Buildings or portions of buildings can't pass final mechanical inspection until code official has received a letter of transmittal from the building owner acknowledging the building owner or owner's authorized agent has received the Preliminary Commissioning Report
- ✓ Code official is permitted to require a copy of the report be made available for review

- ✓ Construction documents to specify that documents described in C408.2.5 be provided to building owner or owner's authorized agent within 90 days of receipt of certificate of occupancy
 - ✓ Drawings
 - ✓ Manuals
 - ✓ System balancing report
 - ✓ Final commissioning report
- ✓ Drawings
 - ✓ Include location and performance data on each piece of equipment

- ✓ O&M manual to be provided to include all of the following:
 - ✓ Submittal data stating equipment size and selected options for each piece of equipment requiring maintenance
 - ✓ Manufacturer's operation and maintenance manuals for each piece of equipment requiring maintenance (except equipment not furnished as part of the project). Required routine maintenance actions to be clearly identified.
 - ✓ Name and address of at least one service agency
 - ✓ HVAC and SWH controls system maintenance and calibration information, including wiring diagrams, schematics, and control sequence descriptions. Desired or field-determined setpoints to be permanently recorded on control drawings at control devices or, for digital control systems, in system programming instructions
 - ✓ Narrative of how each system is intended to operate, including recommended setpoints

- ✓ To include descriptions of the activities and measurements completed per Section C408.2.2 (systems adjusting and balancing)

- ✓ Delivered to building owner or owner's authorized agent, report to be organized with mechanical system and service hot water system findings in separate sections to allow independent review and include:
 - ✓ Results of functional performance tests
 - ✓ Disposition of deficiencies found during testing, including corrective measure details – used or proposed
 - ✓ Functional performance test procedures used during commissioning process including measurable criteria for test acceptance

Exception – deferred tests which can't be performed at time of report preparation due to climatic conditions