

Unvented Attic Assemblies - Code Notes

[2009 IRC, 2012 IRC]

Adequate attic ventilation is a long-standing requirement in building codes for moisture control. However, unvented attics can reduce residential energy needs, and are allowed by the code under certain conditions. Such assemblies are sometimes called cathedralized attics because, as with cathedral ceilings, the insulation is in the rafters and/or the roof deck. The primary benefit of cathedralized attics is the ability to locate HVAC ducts inside conditioned space, where duct leaks and heat losses or gains are not detrimental to the home's energy bill.

Section R806.4 of the 2009 International Residential Code® (IRC), and Section R806.5 of the 2012 IRC have requirements for unvented (conditioned) attic assemblies. The overall insulation level in the roof assembly must meet the baseline requirements for energy efficiency as given in the IRC Section N1102 (or IECC, Section 402). Additionally, there are requirements related to the arrangement of the insulation so as to prevent moisture condensation in the roof assembly. In all but Climate Zones 2B and 3B, the IRC requires air-impermeable insulation in direct contact with the underside of the roof deck. A combination of an air-impermeable insulation and air-permeable insulation directly below it is permitted.

2009 IRC Table R806.4 and 2012 IRC Table R806.5 set minimum requirements for minimum rigid board insulation to be placed on top of the roof deck if air permeable insulation is installed in direct contact with the underside of the roof deck. The addition of the rigid board insulation will keep the monthly average condensing surface temperature at or above 45°F. Note that the additional rigid board insulation is not required if air impermeable insulation is installed in direct contact with the underside of the roof sheathing.

Table 1. Insulation for Condensation Control

Climate Zone	Minimum Rigid Board on Air-Impermeable Insulation R-Value
2B and 3B with tile roof only	0
1, 2A, 2B, 3A, 3B, 3C	R-5
4C	R-10
4A, 4B	R-15
5	R-20
6	R-25
7	R-30
8	R-35

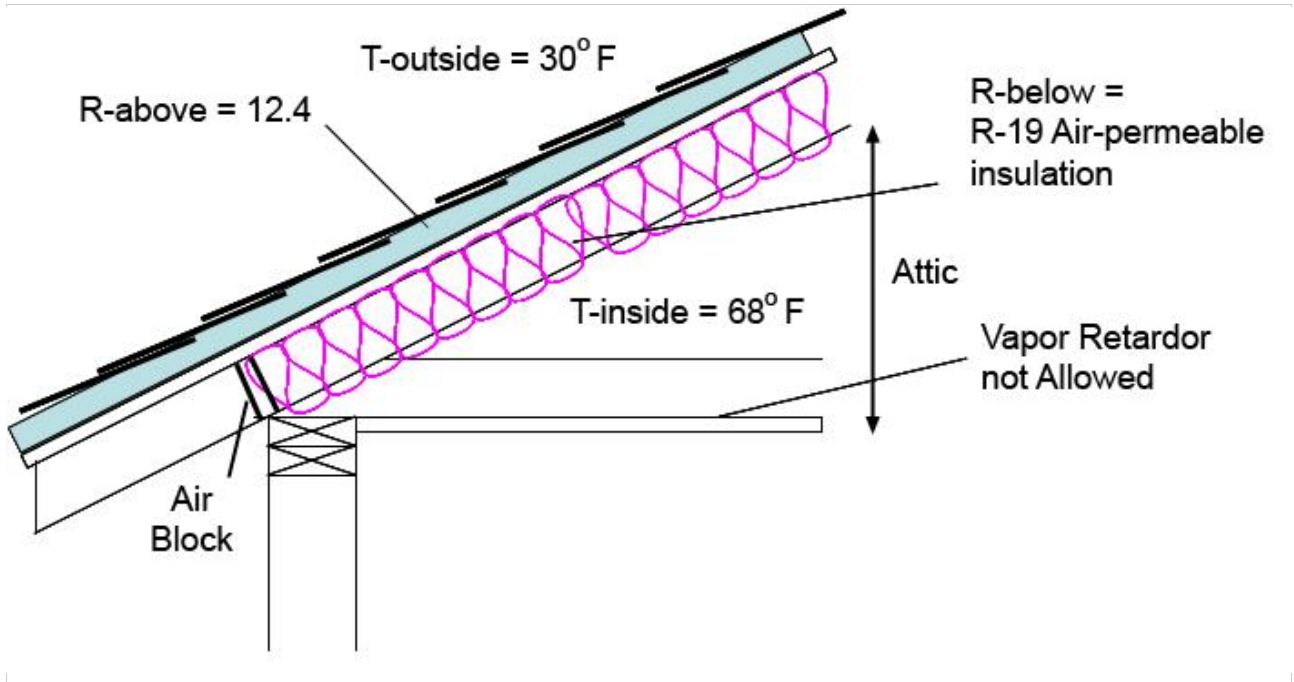

For this example the proposed building is located in Climate Zone 5. The minimum Ceiling R-value requirement based on Section 402.1.2 and Table 402.1.1 is R-38. R-19 air impermeable insulation is proposed to be placed on the underside, and in direct contact, with the roof sheathing. Based on Table R806.4, R-20 rigid board insulation will be required to be placed on top of the roof deck to keep the condensing surface temperature at or above 45°F . The total insulation R-value for the assembly will be an R-39 (R-20 + R-19) which complies with the prescriptive requirements of the 2009 IECC.

The IRC also prohibits a vapor retarder on the attic floor of conditioned attics so that any moisture that may build up in the attic can dissipate into the house. If wood shingles or shakes are used, a $\frac{1}{4}$ -inch air gap must be left above the roof sheathing, but below the shingles or shakes and roofing felt. Air-permeable insulation used in Climate Zones 5 # 8 shall be a vapor retarder, or shall have a vapor retarder installed in direct contact with the underside of the insulation.

Plan Review

1. Verify that the total insulation R-value proposed for the roof assembly meets or exceeds the energy code compliance documentation.
2. For all but Climate Zones 2B and 3B, verify that the insulation in contact with the underside of the roof deck is air-impermeable.
3. For Climate Zones 3 through 8, verify that the correct R-value of rigid board insulation is specified to be placed on top of the roof deck, if air permeable insulation is proposed to be placed under the roof sheathing.
4. In Climate Zones 5 through 8 where air permeable insulation is proposed, verify that a vapor retarder is called out immediately below the insulation. Also verify that a $\frac{1}{4}$ -inch air gap is called out for wood-shingle roof systems.

Field Inspection

1. Verify that roof insulation installed under the roof sheathing is well supported and in substantial contact with the sheathing (if fiberglass batt insulation). For air-impermeable insulation, verify that the installed insulation is the correct thickness to meet the R-value requirement called out on the plans.
2. Verify that the correct R-value of insulation is installed on top of the roof sheathing, if required by code.



3. Verify that a vapor retarder is installed under the air permeable insulation in Climate Zones 5 through 8. Verify that the blocking between trusses and roof members are caulked and sealed, and that any penetration through the roof sheathing is sealed using an approved sealant.

Code Citations*

2009 IRC, Section R806.4; 2012 IRC, Section R806.5, Unvented attic assemblies

Unvented attic assemblies (spaces between the ceiling joists of the top story of the roof rafters) shall be permitted if all of the following conditions are met:

1. the unvented attic space is completely contained within the building thermal envelope
2. no interior vapor retarders are installed on the ceiling side (attic floor) of the unvented attic assembly [2009 IRC]; no interior Class I vapor retarders are installed on the ceiling side (attic floor) of the unvented attic assembly [2012 IRC]
3. where wood shingles or shakes are used, a minimum ¼ inch vented air space separates the shingles or shakes and the roofing underlayment above the structural sheathing
4. in Climate Zones 5, 6, 7 and 8, any air-impermeable insulation shall be a vapor retarder, or shall have a vapor retarder coating or covering in direct contact with the underside of the insulation [2009 IRC]; in Climate Zones 5, 6, 7 and 8, any air-impermeable insulation shall be a Class II vapor retarder, or shall have a Class III vapor retarder coating or covering in direct contact with the underside of the insulation [2012 IRC]
5. either Items 5.1, 5.2 or 5.3 shall be met, depending on the air permeability of the insulation directly under the structural roof sheathing

References

*Copyright, 2009, [International Code Council](#), Inc. Falls Church, Virginia. 2009 International Residential Code. Reproduced with permission. All rights reserved.

Copyright, 2011, [International Code Council](#), Inc. Falls Church, Virginia. 2012 International Residential Code. Reproduced with permission. All rights reserved.